



WORKSHOP MANUAL

633376

Downloaded from www.ScooterTime.net



Vespa PX 150 USA



WORKSHOP MANUAL

Vespa PX 150 USA

Downloaded from www.ScooterTime.net

WORKSHOP MANUAL

Vespa PX 150 USA

This manual has been prepared by Piaggio & C. S.p.A, for use in the workshops of authorized Piaggio-Gilera dealers and sub-agents. It is assumed that the person utilizing this manual for servicing or repairing Piaggio vehicles has knowledge of the principles of mechanics and standard procedures required for general vehicle repair. Any relevant changes concerning the vehicle characteristics or specific repair operations will be divulged in the form of updates to this manual. Satisfactory repair or service cannot be achieved without the necessary equipment and tools. Refer to the pages of this manual concerning specific tools and equipment and the special tools catalogue.

N.B. Provides key information to make the procedure easier to understand and carry out.

CAUTION Refers to specific procedures to carry out for preventing damages to the vehicle.

WARNING Refers to specific procedures to carry out to prevent injuries to the repairer.



Personal safety Failure to completely observe these instructions will result in serious risk of personal injury.



Safeguarding the environment Sections marked with this symbol indicate the correct use of the vehicle to prevent damaging the environment.



Vehicle intactness The incomplete or non-observance of these regulations leads to the risk of serious damage to the vehicle and sometimes even the invalidity of the guarantee.



Downloaded from www.ScooterTime.net

INDEX OF TOPICS

CHARACTERISTICS

CHAR

TOOLING

TOOL

MAINTENANCE

MAIN

ELECTRICAL SYSTEM

ELE SYS

ENGINE FROM VEHICLE

ENG VE

ENGINE

ENG

SUSPENSIONS

SUSP

BRAKING SYSTEM

BRAK SYS

CHASSIS

CHAS

PRE-DELIVERY

PRE DE

TIME

TIME

Downloaded from www.ScooterTime.net

Downloaded from www.ScooterTime.net

INDEX OF TOPICS

CHARACTERISTICS

CHAR

Downloaded from www.ScooterTime.net

Rules

Safety rules

- Should it be necessary to keep the engine running while servicing, make sure that the area or room is well ventilated, and use special exhaust fans, if required. Never let the engine running in closed rooms. In fact, exhaust gases are toxic.
- The battery electrolyte contains sulphuric acid. Protect your eyes, clothes and skin. Sulphuric acid is highly corrosive; in the event of contact with your eyes or clothes, rinse thoroughly with water and consult a doctor immediately.
- The battery produces hydrogen, a gas that can be highly explosive. Do not smoke and avoid sparks and flames when close to the battery, especially during recharge.
- Fuel is highly flammable, and in some conditions it can be explosive. Do not smoke in the working area, and avoid free flames or sparks.
- Clean the brake pads in a well ventilated environment, directing the compressed air jet so as to not intake the dust produced by the wear of the friction material. Even though the latter contains no asbestos, dust inhalation is harmful.

Safety rules

- Use original PIAGGIO spare parts and lubricants recommended by the Manufacturer. Non-original or non-conforming spares may damage the vehicle.
- Use only the specific tools designed for this vehicle.
- Always use new gaskets, sealing rings and split pins upon reassembly.
- After removal, clean the components using non-flammable or low fire-point solvent. Lubricate all working surfaces before reassembly, except for conical couplings.
- After reassembly, check that all components have been installed properly and that they are in good working order.
- For removal, overhaul and reassembly operations use only tools provided with metric measures. Metric bolts, nuts and screws are not interchangeable with coupling members with English measurement. Using improper coupling members and tools may impair the vehicle.
- Should any interventions to the vehicle electric system be required, check that the electrical connections - especially earth and battery connections - have been implemented properly.

Dimensions and mass

WEIGHT AND DIMENSIONS

Specification	Desc./Quantity
Empty weight	229,28 Lb (104 Kg)
Wheelbase	48,62 inch (1235 mm)
Max height	43,70 inch (1110 mm)
Max lenght	69,29 inch (1760 mm)
Handlebars width	27,56 inch (700 mm)

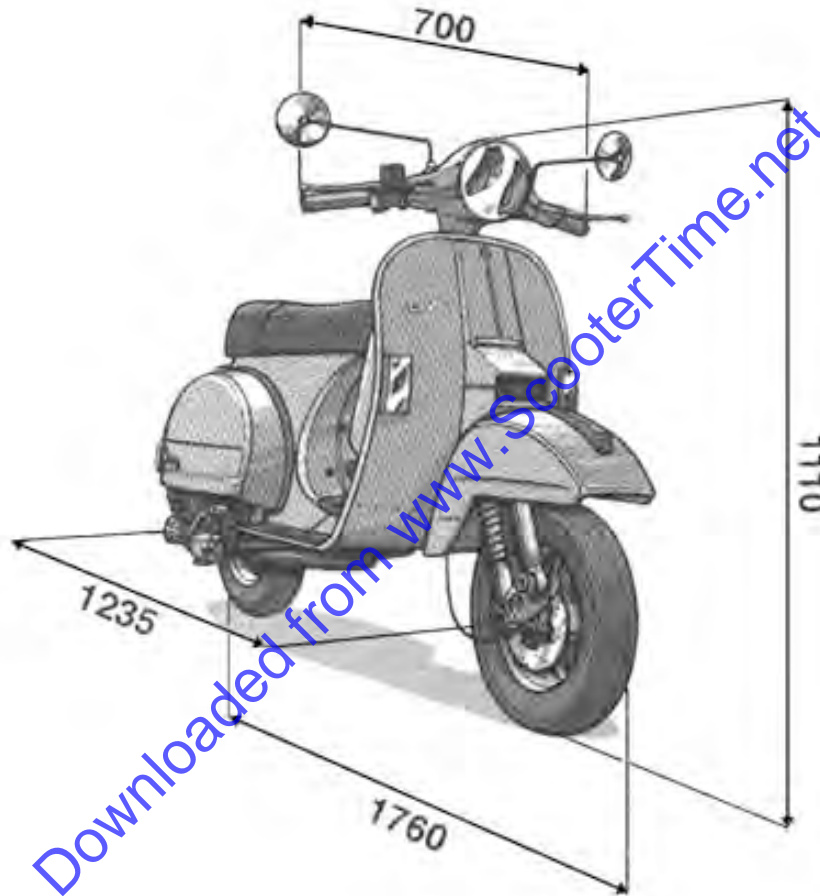

Engine

ENGINE

Specification	Desc./Quantity
Engine type	2-stroke with rotary intake timing
No. of cylinders	1
Alesaggio per corsa (150)	0,19 x 2,24 inch (58 x 57 mm)
Cilindrata (150)	919 inch ³ (150,599 cm ³)

Specification	Desc./Quantity
Compression ratio (150)	8 : 1
Carburetor	Dell'orto SI 20/20 D
Engine idle	1900 ± 100 rpm
CO value	3,8 ± 0,5%
Air filter	Metallic net soaked in oil-petrol mixture
Starting system	Electric starter motor and kick-start
Lubrication	Mixture oil
Fuel supply	Oil-petrol mixture through carburetor with automatic mixer (mass flow varying with engine speed) and throttle valve
Clutch	Multi-disc
Cooling	By forced air with centrifugal fan.
Max power output (shaft) 150cc	6.6 Kw (9 hp) at 5,700 rpm
Max speed (150)	82,8 Km/h

Transmission

TRANSMISSION

Specification	Desc./Quantity
Gear-box	4-speed with constantly engaged gears

Capacities

CAPACITIES

Specification	Desc./Quantity
Gear-box	~ 250 cc.
Mixer oil tank	~ 0,42 gal, including 0,10 gal reserve (~ 1,6 l, including 0,4 l reserve)
Fuel tank	~2,11 gal, including ~0,55 gal reserve (~8 l, including ~ 2,1 l reserve)

Electrical system

ELECTRICAL SYSTEM

	Specification	Desc./Quantity
1	Ignition type	Electronic ignition by capacitive discharge with H.T. coil
2	Spark advance (T.D.C.)	18° ± 1

	Specification	Desc./Quantity
3	Spark plug	CHAMPION RL82C
4	Battery	12V - 9Ah
5	Fuse	7,5A
6	Generator	AC

Frame and suspensions

FRAME AND SUSPENSIONS

Specification	Desc./Quantity
Suspensions	Steering column pivoted onto front wheel hub, helicoid spring suspension and hydraulic shock-absorber (compression and rebound damping)
Frame	Monocoque-type shell obtained from pressed steel

Brakes

BRAKES

Specification	Desc./Quantity
Front	Ø 220 mm disc hydraulically operated via lever mounted on RHS of handlebars
Rear	Ø 140 mm drum with expanding shoes mechanically activated via pedal on RHS of footrest

Wheels and tyres

WHEELS AND TIRES

Specification	Desc./Quantity
Front tire	3,50 x 10"
Rear tire	3,50 x 10"
Rims	Pressed steel
Wheels	Interchangeable with 2.00"×10" pressed steel rims.
Front tire pressure	18,85 PSI (1,3 bar)
Rear tire pressure	26,11 PSI (1,8 bar) 33,36 PSI (2,3 bar) driver and passenger

N.B.

CHECK AND ADJUST TIRE PRESSURE WITH TIRES AT AMBIENT TEMPERATURE. ADJUST PRESSURE ACCORDING TO THE WEIGHT OF THE RIDER AND ACCESSORIES.

Carburettor**150cc Version****Dell'Orto****CARBURETTOR**

Specification	Desc./Quantity
Type	SI20/20D
Diffuser diameter	20 mm
Main jet	98
Slow running jet	45/160
Main air jet	150
Throttle valve (type)	6823.16.64
Emulsifier (code)	BE5
Sprayer	280/100
Starter jet	60/100
Air idling screw	1 3/4

Tightening Torques**STEERING UNIT**

Name	Torque in Nm
Upper steering ring nut	5÷6
Top steering housing	6÷7 (hence loosen by 80° - 90°)
Handlebar fixing screw*	30÷44

FRAME

Name	Torque in Nm
Engine - frame bolt *	61 ÷ 75
Rim - hub fixing nuts (front-rear)	20 ÷ 27
Shock-absorber - frame fixing nut*	30÷40
Shock-absorber - engine bolt*	13 ÷ 23
Rear wheel axle*	75÷90

FRONT SUSPENSION

Name	Torque in Nm
Shock-absorber mounting plate - steering column	20÷27

Name	Torque in Nm
fixing nuts	
Upper shock-absorber fixing nut	30÷40
Lower shock-absorber fixing nut	20÷27
Front wheel axle nut*	60÷100

FRONT BRAKE

Name	Torque in Nm
Reservoir - pipe fitting	8÷12
Pipe - calliper fitting	15÷25
Intermediate pipe fitting	10÷15
Calliper fixing screw*	20÷25
Disc fixing screw*	5÷6
Oil draining screw	10÷12

ENGINE

Name	Torque in Nm
Coils mounting bracket fixing screw	3÷4
Kick-start lever fixing nut	23÷26
Clutch assy. fixing nut	40 ÷ 45
Multi-gear pinion nut	30 ÷ 35
Flywheel fixing nut	60 ÷ 65
Carburettor fixing bolts	16÷20
Clutch cover fixing screws	6÷8
Cylinder head fixing nuts	13÷18
Spark plug	20÷25
Crankcase mating screws	11÷13
Wheel axle nut	90÷110
Gear shifter nuts	12÷15
Starter motor screws	10÷12
Fan cover screws	8÷10
Air-box fixing screws	6÷8
Gear fixing nut	30÷35
Mixer fixing screws	6÷8
Head fixing nuts	16 ÷ 26
Gear-box trunnion	15 ÷ 18

N.B.

* Safety tightenings

IN ORDER TO ENSURE THE CORRECT TIGHTENING TORQUE, LUBRICATE NUTS BEFORE ASSEMBLY.

Overhaul data

Assembly clearances

Cylinder - piston assy.

The cylinder classification must be carried out at 25 mm from the head mating surface on the rod's swinging plane.

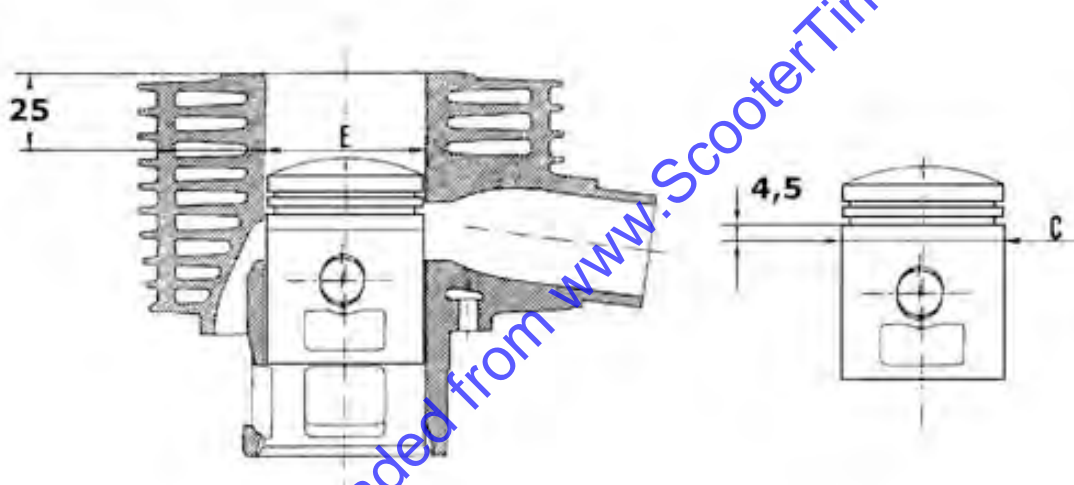

MATING CATEGORIES - 150CC ENGINE

Name	Play	Initials	Cylinder	Piston	Play on fitting
Cylinder - piston	value	B	57,795	57,555	0,240
Cylinder - piston	value	C	57,800	57,650	0,240
Cylinder - piston	value	D	57,805	57,565	0,240
Cylinder - piston	value	E	57,810	57,570	0,240
Cylinder - piston	value	F	57,815	57,575	0,240

Name	Play	Initials	Cylinder	Piston	Play on fitting
Cylinder - piston	value	G	57,820	57,580	0,240
Cylinder - piston	value	H	57,825	57,585	0,240
Cylinder - piston (1st over-size)	value	C	58,000	57,760	0,240
Cylinder - piston (1st over-size)	value	D	58,005	57,765	0,240
Cylinder - piston (1st over-size)	value	E	58,010	57,770	0,240
Cylinder - piston (1st over-size)	value	F	58,015	57,775	0,240
Cylinder - piston (1st over-size)	value	G	58,020	57,780	0,240
Cylinder - piston (2nd over-size)	value	C	58,200	57,960	0,240
Cylinder - piston (2nd over-size)	value	D	58,205	57,965	0,240
Cylinder - piston (2nd over-size)	value	E	58,210	57,970	0,240
Cylinder - piston (2nd over-size)	value	F	58,215	57,975	0,240
Cylinder - piston (2nd over-size)	value	G	58,220	57,980	0,240
Cylinder - piston (3rd over-size)	value	C	58,400	58,160	0,240
Cylinder - piston (3rd over-size)	value	D	58,405	58,165	0,240
Cylinder - piston (3rd over-size)	value	E	58,410	58,170	0,240

Name	Play	Initials	Cylinder	Piston	Play on fitting
Cylinder - piston (3rd over-size)	value	F	58,415	58,175	0,240
Cylinder - piston (3rd over-size)	value	G	58,420	58,180	0,240

Piston rings

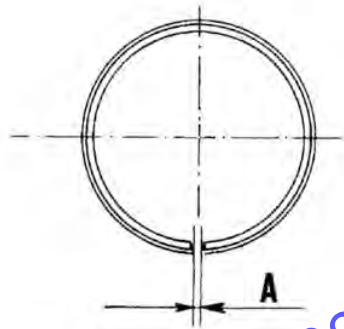

PISTON RINGS - 150CC ENGINE

Name	Description	Dimensions	Initials	Quantity
Piston ring		57,8	A	0,2 ÷ 0,4
Piston ring (1st over-size)		58	A	0,2 ÷ 0,4
Piston ring (2nd over-size)		58,2	A	0,2 ÷ 0,4
Piston ring (3rd over-size)		58,4	A	0,2 ÷ 0,4

Crankcase - crankshaft - connecting rod

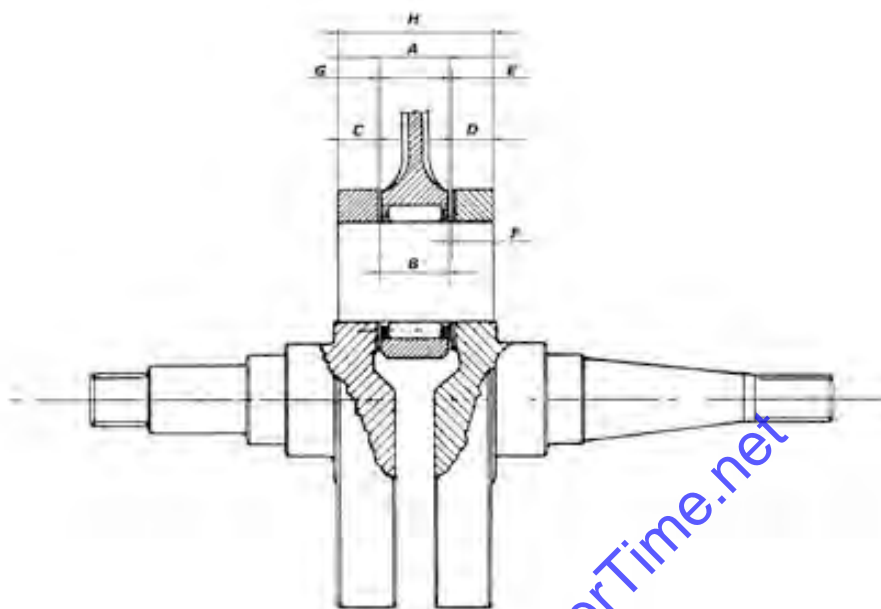

CONNECTING ROD - CRANKSHAFT. ASSEMBLY CLEARANCE «E» BETWEEN BIG END AND HALF CRANKSHAFT ON FLYWHEEL-SIDE

Name	Description	Dimensions	Initials	Quantity
Connecting Rod		A= 15,4 +0 -0,05	E	0,15 ÷ 0,46
Washer (2)		G= 0,5 +0,05 -0,03	E	0,15 ÷ 0,46
Half-crankshaft clutch-side		C= 11,1 -0 +0,05	E	0,15 ÷ 0,46
Half-crankshaft fly-wheel-side		D= 11,1 -0 +0,05	E	0,15 ÷ 0,46
Spacer tool		H= 38,95		

CONNECTING ROD - CRANKSHAFT. ASSEMBLY CLEARANCE «F» BETWEEN BIG END ROLLER CAGE AND HALF CRANKSHAFT ON FLYWHEEL-SIDE

Name	Description	Dimensions	Initials	Quantity
Connecting Rod		B= 15,6 -0,1 -0,2	F	0,05 ÷ 0,41
Washer (2)		G= 0,5 +0,05 -0,03	F	0,05 ÷ 0,41
Half-crankshaft clutch-side		C= 11,1 -0 +0,05	F	0,05 ÷ 0,41
Half-crankshaft fly-wheel-side		D= 11,1 -0 +0,05	F	0,05 ÷ 0,41
Spacer tool		H= 38,95		

- Connecting rods and roller cages are subdivided into **4 categories** (indicated by markings on big end and outer cage rim, respectively)

- Mate connecting rod with cage of same category; if such assembly results to be excessively

noisy, use a roller cage from **next category**.

– For the wrist pin, fitted with 0 clearance, **the maximum allowable play after use must be 0.02 mm.**

– The maximum allowable end-play for the connecting rod **after use** (intended as the longitudinal slide on the big end) **is 0.7mm.**

Gearbox shouldered

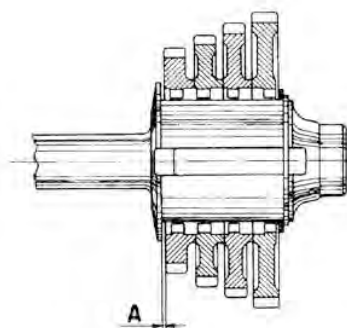

GEARBOX SHOULDERS

Name	Description	Dimensions	Initials	Quantity
Shoulder		2,05 +0 -0,06	A	0,15 ÷ 0,40
Shoulder (1st over-size)		2,20 +0 -0,06	A	0,15 ÷ 0,40
Shoulder (2nd over-size)		2,35 +0 -0,06	A	0,15 ÷ 0,40
Shoulder (3rd over-size)		2,50 +0 -0,06	A	0,15 ÷ 0,40
Shoulder (4th over-size)		2,65 +0 -0,06	A	0,15 ÷ 0,40

N.B.

IF THE SPECIFIED CLEARANCE «A» CANNOT BE ACHIEVED, REPLACE THE SHOULDER RING WITH AN OVERSIZED ONE SUCH TO ALLOW OBTAINING THE PRESCRIBED PLAY. TO CHECK THE CLEARANCE, USE A FEELER GAUGE.

Products

TABLE OF RECOMMENDED PRODUCTS

Product	Description	Specifications
TUTELA ZC GEMAX 6	Gearbox Oil	SAE 80W oil complying with, or exceeding, API GL4 specifications.
SELENIA HI Scooter 2 Tech	Oil for flexible transmission lub-	Oil for two-stroke motors

Product	Description	Specifications
	rication (acceleration control, mixer and km counter)	
SYSTEM TW 249 AREXONS	Grease (brake level, throttle twistgrip, gaer)	Calcium complex soap grease NLGI 1-2
SELENIA HI Scooter 2 Tech	Mixer Oil	Synthetic oil that passes API TC ++ specifications
JOTA 3 FS	Speedometer transmission	Lithium soap grease NLGI 33
TUTELA TOP 4	Brake fluid	Synthetic fluid SAE J1703, NHTSA 116 DOT 4, ISO 4925

Downloaded from www.ScooterTime.net

Downloaded from www.ScooterTime.net





INDEX OF TOPICS





TOOLING

TOOL



Downloaded from www.ScooterTime.net

TOOLING



Stores code	Description	
020004Y	Drift for removing thrust rings from steering head tube	
020055Y	Steering tube ring nut spanner	
020074Y	Crankshaft aligning tool	
002850y	Oil tank spanner	
002973y	Fuel tap spanner	
020320Y	Exhaust gases analyser	

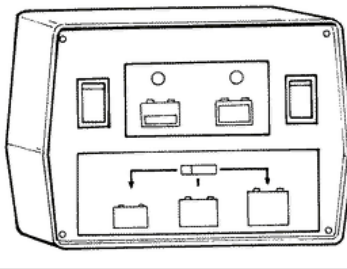

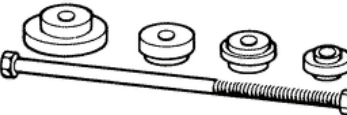

Stores code	Description	
020325y	Pliers for brake-shoe springs	
020329Y	Pump MITYVAC	
020330Y	Stroboscopic gun for two- and four-stroke engines	
020331Y	Digital multimeter	
020332Y	Digital rpm counter	

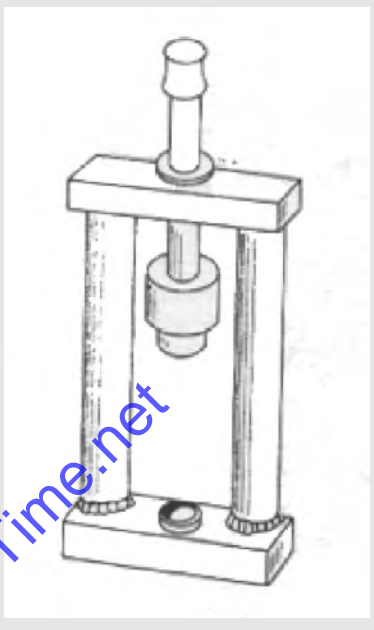
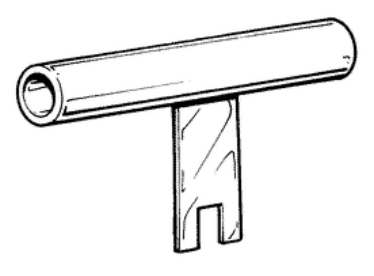
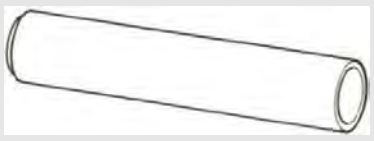
Downloaded from www.ScooterTime.net



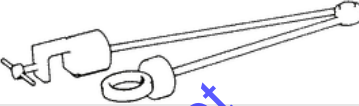

Stores code	Description	
020333Y	Single battery charger	
020334Y	Multiple battery charger	
020335Y	Magnetic stand and comparator	
001330Y	Steering seat installer, to be fitted with parts: 001330Y009-For lower seat, 001330Y013-For upper seat	

Downloaded from www.ScooterTime.net

Stores code	Description	
020021y	Front suspension overhaul kit	 <p>A mechanical press tool with a vertical frame, a central rod, and a handle on top, used for adjusting or compressing suspension components.</p>
020321y	Carburettor float removing tool	 <p>A T-shaped metal tool with a long cylindrical handle and a forked end, used for accessing and removing the float in a carburetor.</p>
006029y	Drift for fitting thrust ring seats on steering tube	 <p>A long, hollow cylindrical metal tube used as a drift to precisely align and seat thrust ring components on a steering tube.</p>
020625Y	Exhaust gases collecting kit	 <p>A kit including a vertical metal rod with a spring at the top, a horizontal pipe, and several small fittings and nuts used for collecting exhaust gas samples.</p>
001467y021	11 mm bearing clip	 <p>A metal bearing clip consisting of a threaded rod with a hexagonal nut and a tapered end, used to secure a bearing in place.</p>

Stores code	Description	
020151Y	Air heater "METABO HG 1500/2"	
020150Y	Support for air heater "METABO HG 1500/2"	
020057Y	Calking tool	
020095Y	Flywheel retaining tool	
008564Y	Flywheel extractor	
008886Y	Crankshaft extractor	
004499y	Bearing extractor	

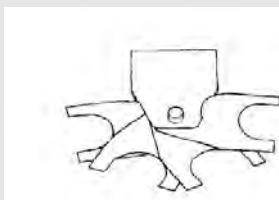
Downloaded from www.ScooterTime.net

Stores code	Description	
020265y	Bearing fitting stand	
060007Y	Crankcase bearing spacer	
060824Y	Inspection probe	
008119y009	Tube (shaft fitting tool)	
001729Y	Clutch retaining tool	
020322Y	Clutch removing/fitting tool	

Downloaded from www.ScooterTime.net

Downloaded from www.ScooterTime.net

INDEX OF TOPICS

MAINTENANCE

MAIN

Downloaded from www.ScooterTime.net

Maintenance chart**EVERY 2 YEARS****Action**

Brake fluid - Change

AT 621,37 MILES OR 4 MONTHS

80'

Action

Gear-box oil level - replacement

Throttle mixer cable - adjustment

Speedometer cable - Grease

Steering - Adjust

Brake and clutch lever - greasing

Brake fluid level - Check

Nuts, bolts and fasteners - Check

Electrical system and battery - Check

Tires-inflation and wear - Check

Vehicle and brake test - Road test

AT 3106,86 MILES OR 12 MONTHS

65'

Action

Gear-box oil level - check

Spark plug - Replace

Air filter on carburetor - Clean

Throttle mixer cable - adjustment

Brake and clutch lever - greasing

Brake pads - Check condition + wear

Brake fluid level - Check

Electrical system and battery - Check

Tires condition and wear - Check

Vehicle and brake test - Road test

AT 6213,71 MILES OR 24 MONTHS

130'

Action

Gear-box oil level - replacement

Action

Spark plug - Replace
Air filter on carburetor - Clean
Idling speed (*) - Adjustment
Throttle mixer cable - adjustment
Speedometer cable - Grease
Steering - Adjust
Brake and clutch lever - greasing
Brake pads - Check condition + wear
Brake fluid level - Check
Transmissions - Lubricate
Nuts, bolts and fasteners - Check
Suspensions - Check
Electrical system and battery - Check
Headlight - adjustment
Tires condition and wear - Check
Vehicle and brake test - Road test

(*) See regulations in section «Idling speed adjustment»

AT 9320,57 MILES OR 36 MONTHS

65'

Action

Gear-box oil level - check
Spark plug - Replace
Air filter on carburetor - Clean
Throttle mixer cable - adjustment
Brake and clutch lever - greasing
Brake pads - Check condition + wear
Brake fluid level - Check
Electrical system and battery - Check
Tires condition and wear - Check
Vehicle and brake test - Road test

AT 12427 MILES

135'

Action

Gear-box oil level - replacement

Action

Spark plug - Replace

Air filter on carburetor - Clean

Idling speed (*) - Adjustment

Cylinder cooling system - Check/Clean

Throttle mixer cable - adjustment

Speedometer cable - Grease

Steering - Adjust

Brake and clutch lever - greasing

Brake pads - Check condition + wear

Brake fluid level - Check

Transmissions - Lubricate

Nuts, bolts and fasteners - Check

Suspensions - Check

Electrical system and battery - Check

Headlight - adjustment

Tires condition and wear - Check

Vehicle and brake test - Road test

(*) See in section «Idling speed adjustment»

AT 15534 MILES

65'

Action

Gear-box oil level - check

Spark plug - Replace

Air filter on carburetor - Clean

Throttle mixer cable - adjustment

Brake and clutch lever - greasing

Brake pads - Check condition + wear

Brake fluid level - Check

Electrical system and battery - Check

Tires condition and wear - Check

Vehicle and brake test - Road test

AT 18641 MILES

160'

Action

Gear-box oil level - replacement

Spark plug - Replace

Air filter on carburetor - Clean

Idling speed (*) - Adjustment

Throttle mixer cable - adjustment

Speedometer cable - Grease

Steering - Adjust

Brake and clutch lever - greasing

Brake pads - Check condition + wear

Flexible brake lines - Change

Brake fluid level - Check

Transmissions - Lubricate

Nuts, bolts and fasteners - Check

Suspensions - Check

Electrical system and battery - Check

Headlight - adjustment

Tires condition and wear - Check

Vehicle and brake test - Road test

(*) See regulations in section «Idling speed adjustment»

AT 21748 MILES

65'

Action

Gear-box oil level - check

Spark plug - Replace

Air filter on carburetor - Clean

Throttle mixer cable - adjustment

Brake and clutch lever - greasing

Brake pads - Check condition + wear

Brake fluid level - Check

Electrical system and battery - Check

Tires condition and wear - Check

Vehicle and brake test - Road test

AT 24855 MILES

145'

Action

Gear-box oil level - replacement

Spark plug - Replace

Air filter on carburetor - Clean

Idling speed (*) - Adjustment

Cylinder cooling system - Check/Clean

Throttle mixer cable - adjustment

Speedometer cable - Grease

Steering - Adjust

Brake and clutch lever - greasing

Brake pads - Check condition + wear

Brake fluid level - Check

Transmissions - Lubricate

Nuts, bolts and fasteners - Check

Suspensions - Check

Electrical system and battery - Check

Headlight - adjustment

Tires condition and wear - Check

Vehicle and brake test - Road test

(*) See regulations in section «Idling speed adjustment»

AT 27962 MILES

65'

Action

Gear-box oil level - check

Spark plug - Replace

Air filter on carburetor - Clean

Throttle mixer cable - adjustment

Brake and clutch lever - greasing

Brake pads - Check condition + wear

Brake fluid level - Check

Electrical system and battery - Check

Tires condition and wear - Check

Vehicle and brake test - Road test

AT 31069 MILES

130'

Action

Gear-box oil level - replacement

Spark plug - Replace

Air filter on carburetor - Clean

Idling speed (*) - Adjustment

Throttle mixer cable - adjustment

Speedometer cable - Grease

Steering - Adjust

Brake and clutch lever - greasing

Brake pads - Check condition + wear

Brake fluid level - Check

Transmissions - Lubricate

Nuts, bolts and fasteners - Check

Suspensions - Check

Electrical system and battery - Check

Headlight - adjustment

Tires condition and wear - Check

Vehicle and brake test - Road test

(*) See regulations in section «Idling speed adjustment»

AT 34175 MILES

65'

Action

Gear-box oil level - check

Spark plug - Replace

Air filter on carburetor - Clean

Throttle mixer cable - adjustment

Brake and clutch lever - greasing

Brake pads - Check condition + wear

Brake fluid level - Check

Electrical system and battery - Check

Tires condition and wear - Check

Vehicle and brake test - Road test

AT 37282 MILES

205'

Action

Gear-box oil level - replacement

Spark plug - Replace

Air filter on carburetor - Clean

Idling speed (*) - Adjustment

Cylinder cooling system - Check/Clean

Throttle mixer cable - adjustment

Speedometer cable - Grease

Steering - Adjust

Brake and clutch lever - greasing

Brake pads - Check condition + wear

Flexible brake lines - Change

Brake fluid level - Check

Transmissions - Lubricate

Nuts, bolts and fasteners - Check

Suspensions - Check

Electrical system and battery - Check

Headlight - adjustment

Tires condition and wear - Check

Vehicle and brake test - Road test

(*) See regulations in section «Idling speed adjustment»

Carburettor

Disassemble the carburetor and clean all components with solvent, hence dry with compressed air all ducts, in order to ensure proper cleaning.

- Carefully check the state of each component.
- The throttle valve must be free to slide inside the mixture chamber; replace if excessive play is found.
- If the mixture chamber is excessively worn, such to prevent the sliding of the throttle valve (although new), replace

the carburetor.

- All seals should be replaced upon re-assembly.

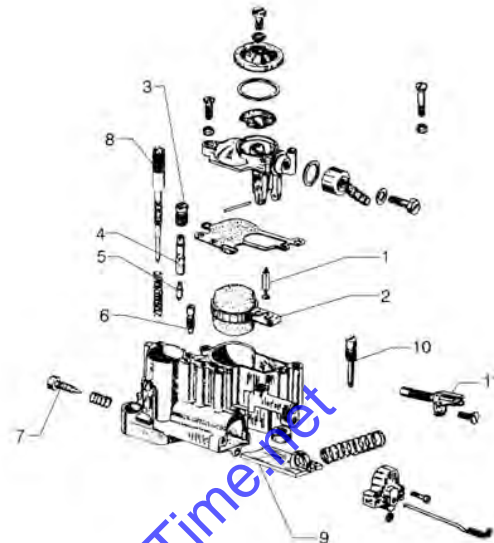

CARBURETOR

Specification	Desc./Quantity
Conical needle	
Float	
Emulsifier air adjusting screw	
Emulsifier	
Main jet	
Slow-running jet	
Fuel flow adjusting screw	
Throttle valve adjusting screw	
Throttle valve	
Starter jet	
Choke device	

Checking the spark advance

In order to ensure the correct timing, check the stator is oriented so that the I.T. index (see figure) coincides with the marking found on the crank-case.

- To check the timing, use a timing light, connect-

ing it to the H.T. cable via the clip provided and then starting the engine.

- The correct spark advance is obtained when, with the engine running between 2,500 and 3,000 rpm, the «P» index is aligned ($\pm 1^\circ$) with the I.T. marking stamped on the volute.
- In the impossibility of obtaining the specified values, or if the engine is found to be running rough, proceed by replacing defective components.

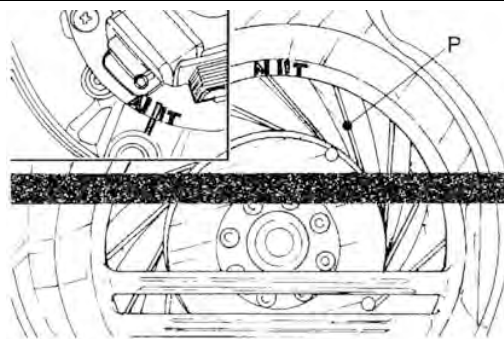

Specific tooling

020330Y Stroboscopic gun for two- and four-stroke engines

020332Y Digital rpm counter

Spark plug

- Detach the spark plug cap
- Carefully inspect the spark plug and replace it if the insulator is damaged
- Using a feeler gauge, measure the spark gap, and adjust it if necessary
- Ensure the sealing washer is in good state
- Refit the spark plug by screwing it in by hand, and tightening it at the prescribed torque using a box spanner

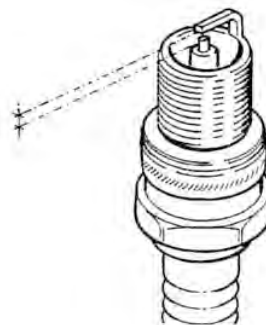

Electric characteristic

Spark plug

CHAMPION RL82C

Spark gap

0,5 ÷ 0,6 mm

Locking torques (N*m)

Spark plug 25 - 30 Nm

Air filter

- Remove the engine cowling and the air-box cover by loosening the four fixing screws shown in the figure and the idle adjusting screw; hence release the filter.
- Clean the filter with 50% fuel-oil mixture, hence dry it with compressed air.

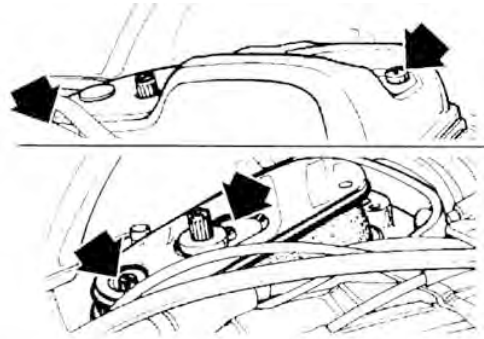

Recommended products

SELENIA HI Scooter 2 Tech Mixer Oil

Synthetic oil that passes API TC ++ specifications

Headlight adjustment

Proceed as follows:

Place the vehicle, in riding order and with the tyres inflated to the prescribed pressure, on flat ground, 32,81 feet (10 m) away from a half-lit white screen. Ensure the vehicle axis is perpendicular to the screen; Turn the headlight on and check the projection of the light beam is between 7/10 and 9/10 of the distance measured from the ground to the centre of the headlight; Adjust the headlight as necessary, via screw «A».



WARNING

THE PROCEDURE DESCRIBED ABOVE COMPLIES WITH THE "EURONORM" CONCERNING THE MAX. AND MIN. HEIGHT OF THE LIGHT BEAM OF A ROAD VEHICLE. PLEASE CHECK WITH THE LOCAL AUTHORITIES FOR WHAT REQUIREMENTS MUST BE FULFILLED IN EVERY SINGLE COUNTRY WHERE THE VEHICLE IS TO BE USED.

Gearbox Oil

- Check for the presence of oil inside the gearbox (oil capacity ~8,82 oz)

(~250 g)); with the vehicle axis perfectly vertical, the oil level must be at the height of inspection hole «A».

- To replace the oil, drain the box using filler hole «B».
- Pour some fresh oil and let the engine run for a few seconds, hence drain the box again.
- Pour 8,82 oz (250 g) of fresh oil through hole «A», so that the level reaches the reference height.

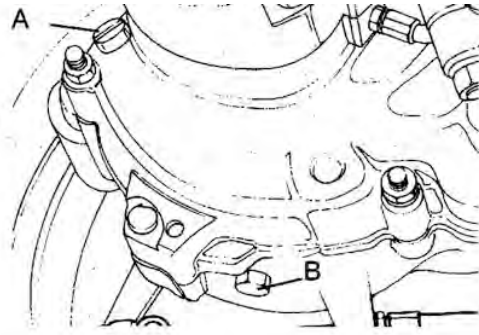

Recommended products

TUTELA ZC GEMAX 6 Gearbox Oil

SAE 80W oil complying with, or exceeding, API GL4 specifications.

Downloaded from www.ScooterTime.net

INDEX OF TOPICS

ELECTRICAL SYSTEM

ELE SYS

Downloaded from www.ScooterTime.net

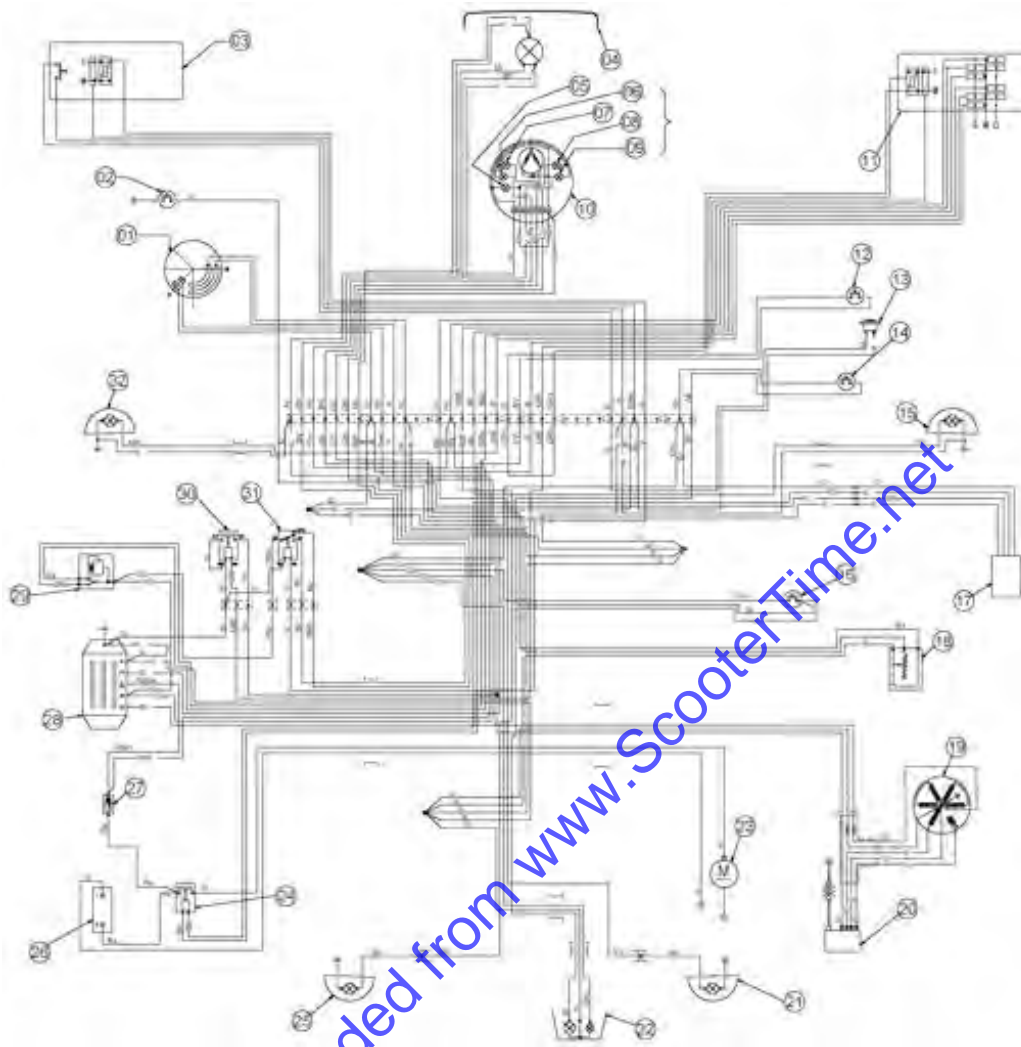

Ar = Orange, **Az** = Light blue, **Bl** = White, **Bl** = Blue, **Gi** = Yellow, **Gr** = Grey, **Ma** = Brown, **Ne** = Black, **Ro** = Pink, **Rs** = Red, **Ve** = Green, **Vi** = Purple.

LEGENDA

	Specification	Desc./Quantity
1	Rear stop light switch	
2	Light switch with flash	
3	Turn signal switch	
4	Horn button	
5	Horn	
6	2 yellow lights for turn signal lights	
7	Front L.H. turn signal light	
8	Heating control device	
9	Flywheel magneto	

	Specification	Desc./Quantity
10	Control device ignition	
11	Starter motor	
12	Fuse carrier (N° 1 fuse to 7,5 A)	
13	Battery	
14	Rear L.H. turn signal light	
15	Direction indicator lights (N° 2)	
16	Rear parking and stop light bulbs	
17	Taillight assembly	
18	Rear R.H. turn signal light	
19	Voltage regulator	
20	Low-oil warning light switch	
21	Starter relay	
22	Frame earth	
23	Starter motor wire unit	
24	Automatic starter	
25	Heater	
26	Chassis wire unit	
27	Fuel level thermistor	
28	Front R.H. turn signal light	
29	Ignition key-switch	
30	Starter button	
31	Front brake stop light switch	
32	Headlight	
33	Light	
34	Sidelight bulb	
35	left turn indicator warning light	12V-2W
36	Headlamp warning light	
37	High-beam lamp warning light	
38	License plate light bulb	
39	Low-fuel warning light	
40	Right turn indicator warning light	12V-2W
41	Low-oil warning light	
42	Odometer with warning lights and level gauges	

Components arrangement

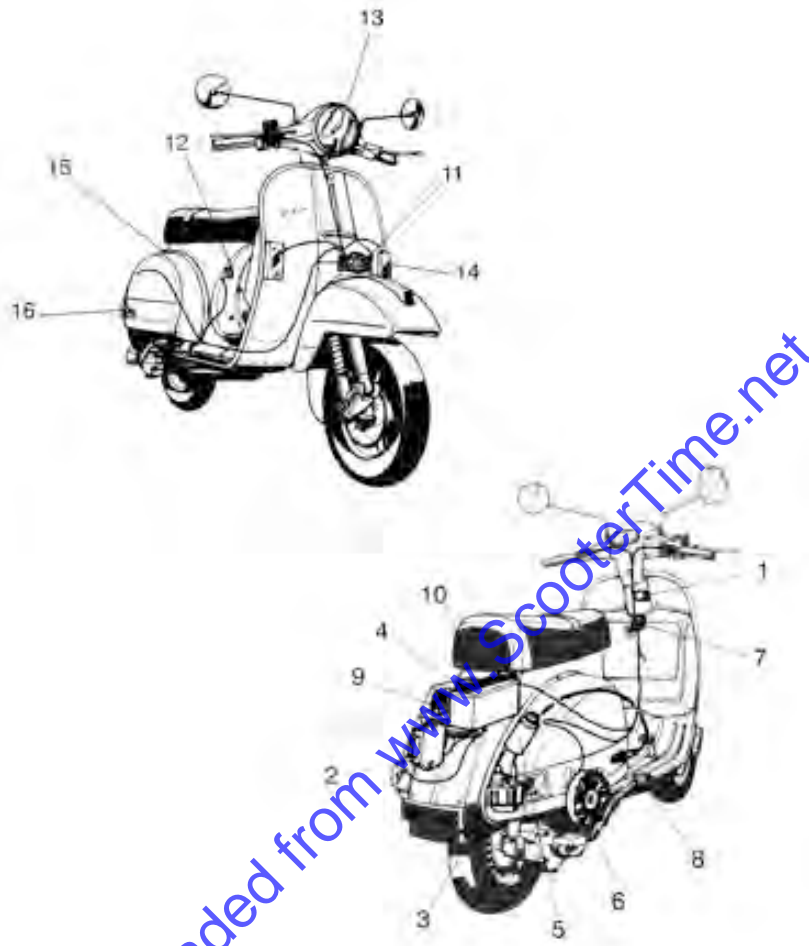

COMPONENTS ARRANGEMENT

	Specification	Desc./Quantity
1	Key-switch	
2	Voltage regulator	
3	Electronic Control Unit (C.D.I.) with H.T coil	
4	Battery	12V - 9Ah
5	Starter motor	
6	Magneto flywheel	
7	Anti-repeating device	
8	Spark plug	
9	Remote starter switch	
10	Fuse	7,5A
11	Horn	

	Specification	Desc./Quantity
12	Turn signals master-box	
13	Front headlight	
14	Front turn signal lights	
15	Taillight	
16	Rear turn signal lights	

Conceptual diagrams

Ignition

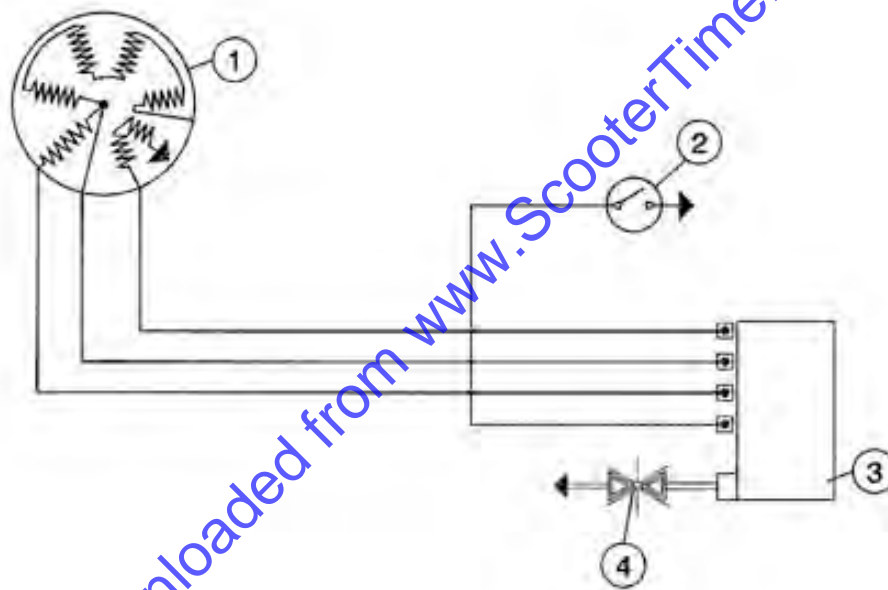

IGNITION

	Specification	Desc./Quantity
1	Magneto flywheel	
2	Key switch contacts	
3	Electronic Control Unit (C.D.I.) with H.T coil	
4	Spark plug	

Headlights and automatic starter section

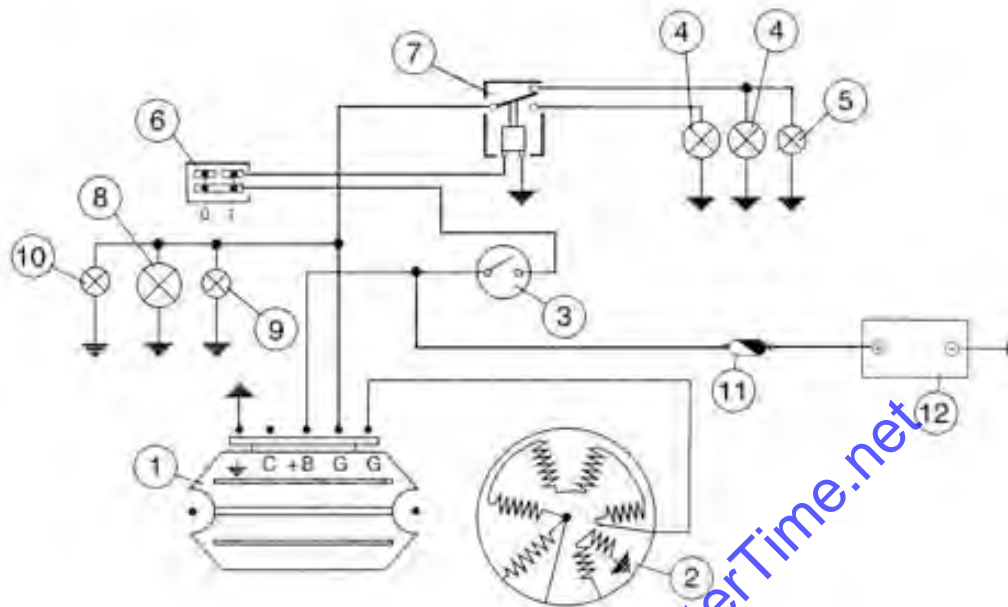

FANALERIA

	Specification	Desc./Quantity
1	Voltage regulator	
2	Magneto flywheel	
3	Key switch contacts	
4	Lampada proiettore	12V-55/60W
5	High beam warning light bulb	12V-1,2W
6	Light switch with flash	
7	Light remote control switch	
8	Rear side light bulb	12V - 5W
9	Instrument panel lighting bulb	12V-1,2W
10	Headlamp warning light	12V - 1,2W
11	Fuse 7,5A	
12	Battery	12V - 9Ah

Battery recharge and starting

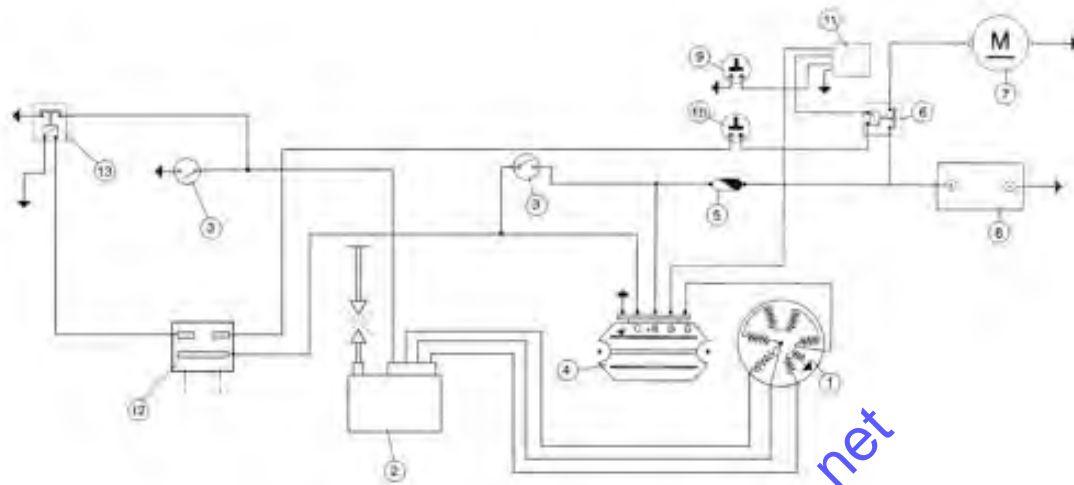

RICARICA BATTERIA E AVVIAMENTO

Specification	Desc./Quantity	
1	Magneto flywheel	
2	Control device ignition	
3	Key switch contacts	
4	Voltage regulator	
5	Fuse	7,5A
6	Remote starter switch	
7	Starter motor	
8	Battery	12V - 9Ah
9	Enable button	
10	Start up button	
11	Anti-repeating device	
12	Engine stop switch	
13	Engine stop remote control switch	

Level indicators and enable signals section

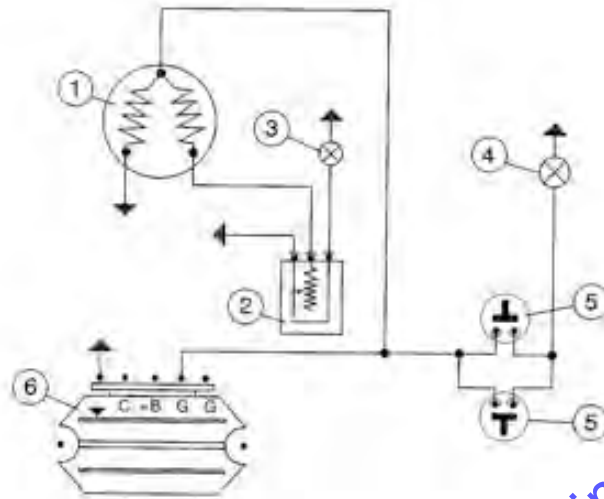

SAFETY SWITCHES AND LEVEL GAUGES

	Specification	Desc./Quantity
1	Fuel level gauge	
2	Fuel level sending unit	
3	Reserve fuel light	12V-1,2W
4	Brake light bulbs	12V-10W
5	Stoplight switches	
6	Voltage regulator	

Turn signal lights

Downloaded from www.ScooterTime.net

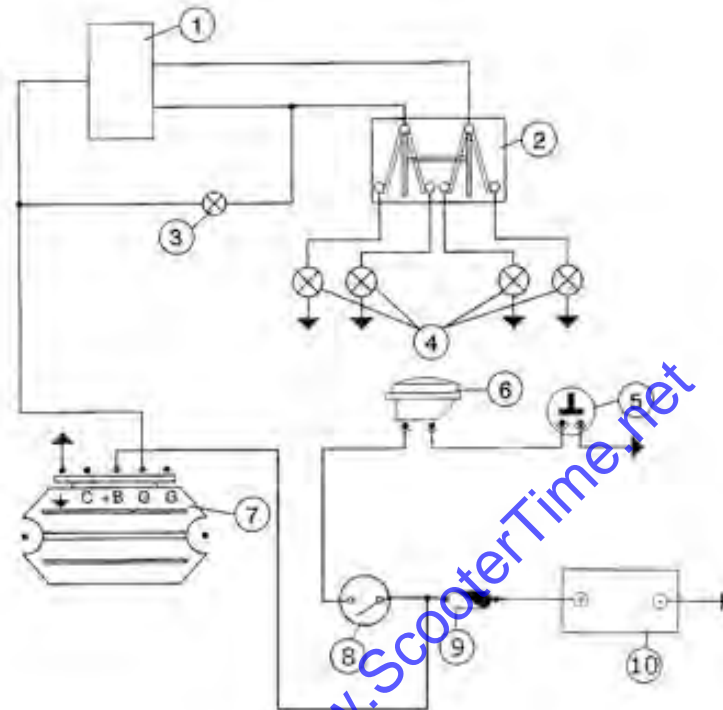

SIGNAL LIGHTS AND HORN

	Specification	Desc./Quantity
1	Turn signals master-box	
2	Indicators switch	
3	Turn signal warning light	12V - 1,2W
4	Turn signal light bulbs	12V - 21W
5	Horn button	
6	Horn	
7	Voltage regulator	
8	Heater control device	
9	Fuse 7,5A	
10	Battery	12V - 9Ah

Instruments and warning lights control board

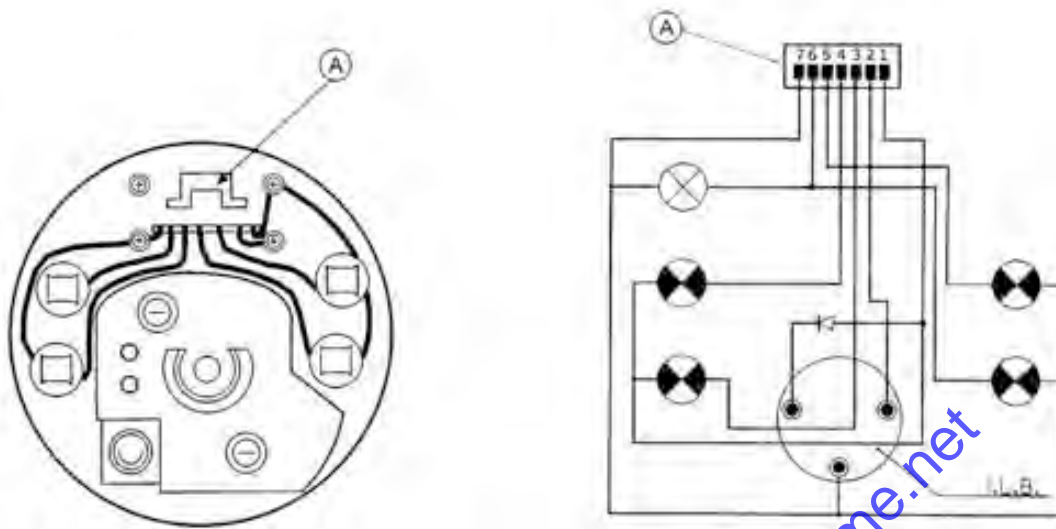

DASHBOARD LIGHTS AND GAUGES

	Specification	Desc./Quantity
1	+ Battery	
2	Fuel gauge	
3	Low fuel warning light	
4	Turn signals warning light	
5	High-beam warning light	
6	Side-lamps warning light	
7	Earth (-)	

Checks and inspections

Ignition circuit

All system checks requiring the detachment of cables (inspections involving ignition system wiring and devices) must be carried out with the engine off, so to avoid any possible damage to the ECU, which would require its replacement. It is therefore important to follow the wire color coding when reattaching the cables (see figure)

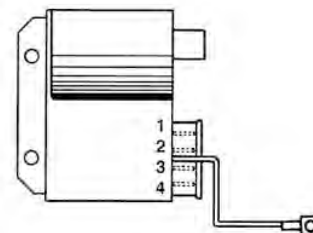

IGNITION CIRCUIT

	Specification	Desc./Quantity
1	WHITE	
2	RED	
3	GREEN	
4	GREEN	

Stator check

In the event of a malfunctioning of the ignition system, with no evident cause, it will be necessary to replace the ECU.

– Remember that all wires can only be detached with the engine off.

– If the ignition system is found to be working properly once the new ECU has been fitted, then the cause of the problem is obviously to be attributed to a defective CDI device.

– In the event that the ignition system is still malfunctioning, it will be necessary to check the generator and the stator components, as follows:

After an eye inspection of the connections, perform measurements on recharge coil and pick-up (see table) using the specified tester. If such readings do not match the stated values, proceed by replacing the stator and its components.

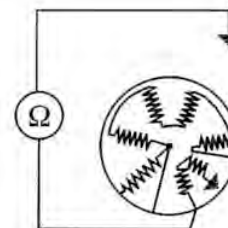
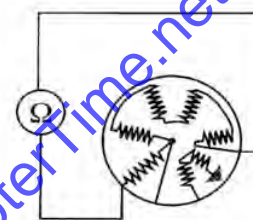
**Specific tooling**

020331Y Digital multimeter

STATOR CHECK

	Specification	Desc./Quantity
1	RED - WHITE wire	90 ÷ 140 ohm
2	GREEN - WHITE wire	800 ÷ 1100 ohm

Voltage regulator check

In the event of suspicious malfunctioning of the voltage regulator, proceed with the following checks:

Alternate current section

Failure of the alternate current section of the voltage regulator may cause, according to the type of fault, the following inconveniences:

1. Blown light bulbs (regulator open-circuited).
2. Failure of the lighting system and automatic choke device (regulator short-circuited).

Interventions

FAULT 1

Replace the regulator, since this is faulty.

FAULT 2

- a) Check the correct current supply from the alternator: detach the regulator connector and attach the tester between the grey-blue wire connection and earth. With the tester set on alternate current, check the supplied voltage at 3,000 rpm is between 25 and 30 V.
- b) If no faults are found, replace the voltage regulator.
- c) If the system is still malfunctioning after the regulator has been replaced, check the connections of the electrical system.

Direct current section

Failure of the regulator's direct current section may cause, depending on the type of failure, the following inconveniences:

3. Blown fuse (regulator short-circuited), resulting in the catastrophic failure of the battery recharging system.
4. Battery recharge faulty (regulator open-circuited).

Interventions

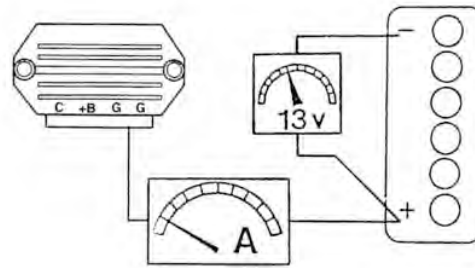

FAULT 3

Replace the regulator, certainly faulty, and the fuse.

FAULT 4

a) Attach an ammeter between the voltage regulator and the battery, and check that, at 3,000 rpm and with the battery at 13 V, the current supplied is approximately 1.5 - 2 A.

If the measured values are below this limit, replace the voltage regulator.

b) If the regulator replacement does not solve the problem, check, using the specified tester, for peaks in the alternate currents between the yellow wire connection and the red wire to the positive battery pole. The voltage supplied by the generator must be between 26 and 30 V, at 3,000 rpm (this measurement must obviously be carried out with the battery disconnected).

Specific tooling

020331Y Digital multimeter

Starter motor**Bench tests to be performed on the electric starter motor**

- 1) No-load test: the starter motor, unloaded, must absorb less than 10 A with a voltage supply > 11.7 V and must spin at more than 18,000 rpm.
- 2) Load test: load the starter motor so that the absorbed current is equal to 40 A, and the supplied voltage is 10 V. In such conditions, the output torque provided must 0.014 Nm, at a speed of no less than 10,000 rpm.
- 3) Breakaway test: with the rotor restrained and supplied voltage of 7 V, the absorbed current must not be higher than 100 A and the torque not less than 0.033 Nm.

N.B.

ALL THESE CHARACTERISTICS MUST BE MEASURED WITH CHARGED BATTERY AND AFTER RUNNING THE MOTOR FOR 30" IN THE CONDITIONS STATED IN 1.

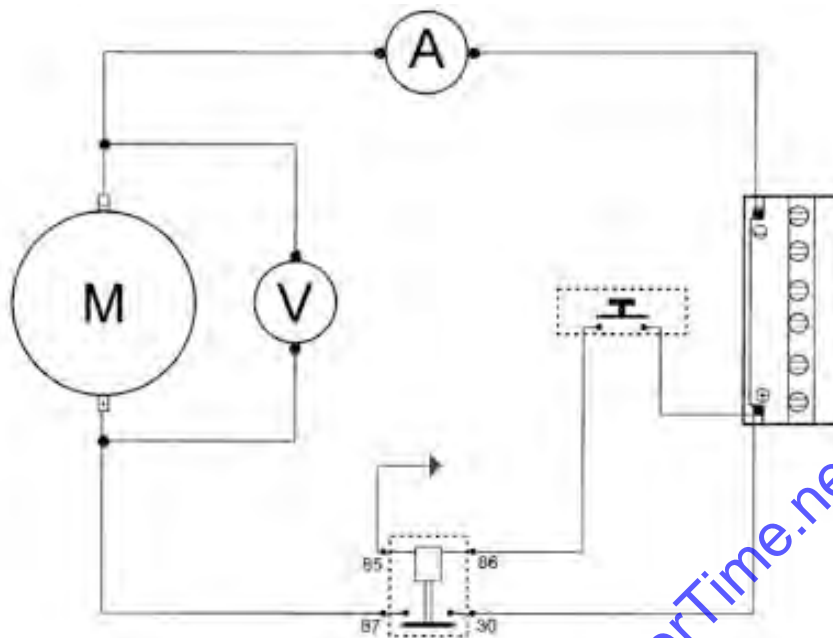

STARTER MOTOR

	Specification	Desc./Quantity
1	Nominal voltage	12V
2	Nominal power	0,15 kW
3	Direction of rotation	Clockwise
4	Engine connection	Via pinion and gear ring on crankshaft, transmission-side
5	Control	Pushbutton
6	Battery	12V - 9Ah

Fuses

The starter system and horn are protected by a 7.5A fuse, «A», located on the LHS of the battery tray. Before replacing a burst fuse, it is necessary to find the cause of the failure. Never attempt to close the circuit with any material other than the fuse.



BEFORE REPLACING THE BLOWN FUSE, TRY TO ELIMINATE THE FAULT THAT HAS CAUSED IT TO BLOW. NEVER TRY TO REPLACE A FUSE USING

DIFFERENT MATERIAL (FOR EXAMPLE A PIECE OF ELECTRIC WIRE).



MODIFICATIONS OR REPAIRS TO THE ELECTRIC SYSTEM CARRIED OUT INCORRECTLY OR WITHOUT TAKING NOTE OF THE SYSTEM'S TECHNICAL CHARACTERISTICS, CAN CAUSE FUNCTION ANOMALIES AND FIRE HAZARD.

Dry-charge battery

BATTERY START UP WITH DRY CHARGE

- Remove the battery ventilation duct closing cap and remove the caps from the single elements.
- Fill the battery with electrolyte having a density of 1.270+/-0.01 Kg/l (corresponding to 31+/-1 Bé) with minimum ambient temperature of 59°F (15°C), up to the top level indicated on the single block.
- Slightly tilt the battery to remove any air bubbles formed during the filling.
- Place the caps on the filling holes of the single elements without tightening them and let the battery stand. During this phase, the battery undergoes a gasification phenomenon and temperature rises.
- Let it stand until ambient temperature is reached again (this phase may require up to 60 minutes).
- Slightly tilt the battery to favour the removal of any air bubbles, then restore the levels using the same electrolyte.

Note: This is the last time that electrolyte can be added. Future top ups must be made using only distilled water:

- Within 24 hours, refill as follows:
- Connect the battery charger terminals according to the right polarity;
- Using the battery charger dwg. 020333Y and/or dwg. 020334Y, select the battery capacity;
- If the battery charger is not available, charge the battery with a constant current of 1/10 of the rated capacity (for example for a battery with rated capacity of 9Ah, the charge current must be 0.9-1.0A), for approx. 4-6 hours.

Note: Batteries stored for a long time can require longer times. Battery chargers dwg. 020333Y and dwg. 020334Y have an automatic protection that stops the recharge after 12 hours to prevent overheating the battery. In this case, the turning on of the green led does not indicate the end of the charge but the start of the safety system.

- Let the battery stand with open circuit for approx. 4-6 hours, then check the voltage using a normal tester.
- If the open circuit voltage is more or equal to 12.6V, the battery charge is good. Slightly tilt the bat-

tery to eliminate any air bubbles formed while recharging.

- Check the electrolyte level again, restore if required up to the tol reference using distilled water, tighten the caps of the single elements and install it on the vehicle.

- If lower voltages are detected, recharge the battery for 4-6 hours more as described above.

Note: With battery charger dwg. 020334Y you can check the battery charge level by the function Check. The value shown on the display must be higher than that indicated in the table; if not, recharge as described above.

Downloaded from www.ScooterTime.net

INDEX OF TOPICS

ENGINE FROM VEHICLE

ENG VE

Downloaded from www.ScooterTime.net

Exhaust assy. Removal

- Remove the two fasteners, exhaust pipe-manifold and then the bolt fixing the exhaust to the engine.

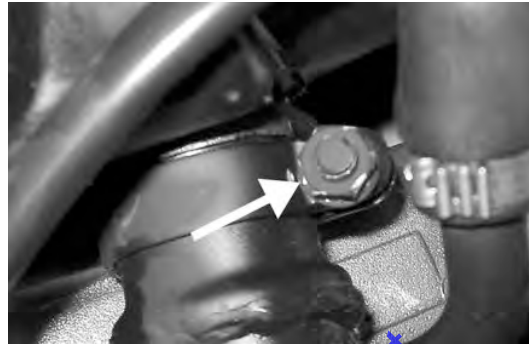

Removal of the engine from the vehicle

- Remove the exhaust assy.
- Remove the rear wheel.
- Detach the rear brake cable.
- Detach the electrical wires.
- Detach the gear shifter cables.
- Remove the throttle and choke cables.
- Detach the oil and petrol hoses.
- Remove the engine-frame bolt shown in the figure.

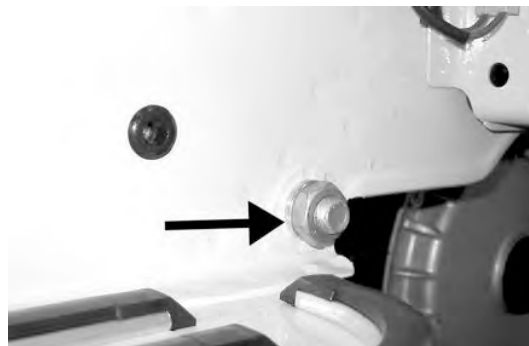
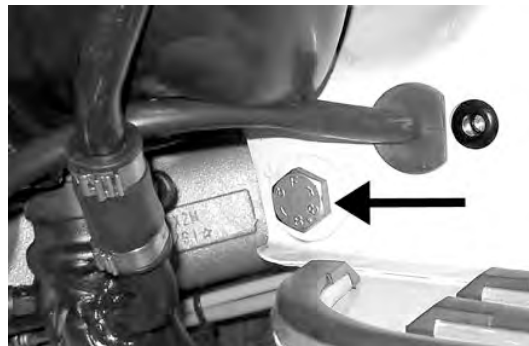

-
- Remove the rear shock-absorber fixing nut and hence the bolt.
 - For the reassembly, follow the above operations in reverse order, using the prescribed tightening torques.

CAUTION

WHEN INSTALLING THE BATTERY, FIRST FIX THE POSITIVE CABLE AND THEN THE NEGATIVE CABLE.

WARNING

BEATING TOOLS SHOULD BE USED WEARING SAFETY GLASSES.

WARNING

PAY THE UTMOST ATTENTION WHEN HANDLING PETROL.

Locking torques (N*m)

Engine - frame bolt * 61 ÷ 75 Shock-absorber - engine bolt* 13 ÷ 23

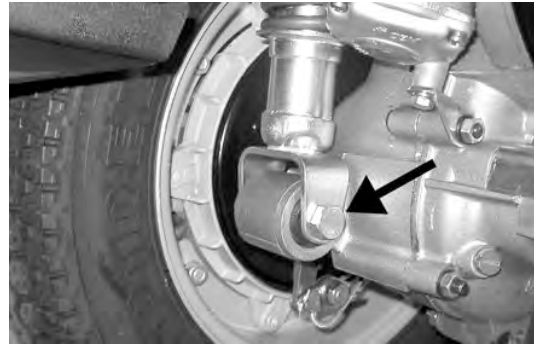

Downloaded from www.ScooterTime.net

Downloaded from www.ScooterTime.net

INDEX OF TOPICS

ENGINE	ENG
---------------	------------

Downloaded from www.ScooterTime.net

Flywheel cover

Cooling hood

- Remove the three fixing screws shown in the figure and the cooling hood.

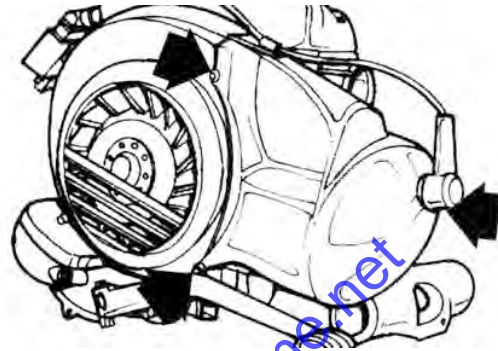

- Remove the fixing screws shown and hence detach the volute and the gear shifter cover.
- Remove the kick-start lever after having detached the lower fastener.

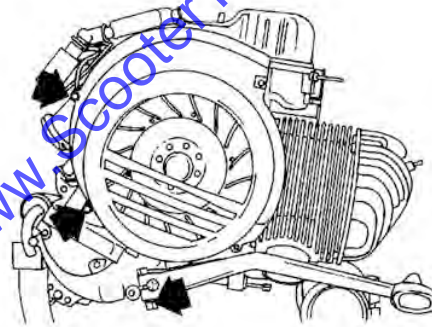

Removing the stator

- Remove the three screws shown in the figure.
- Remove the stator.

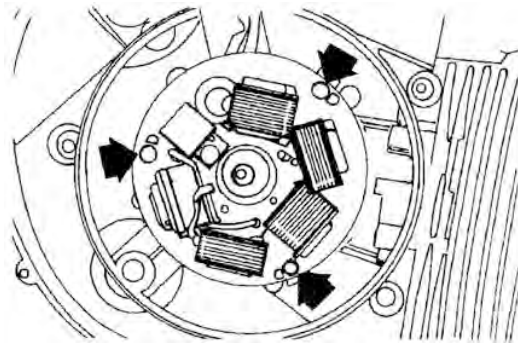

Refitting the stator

In order to guarantee the correct engine timing pay attention to the position of the stator, as

shown in the figure.

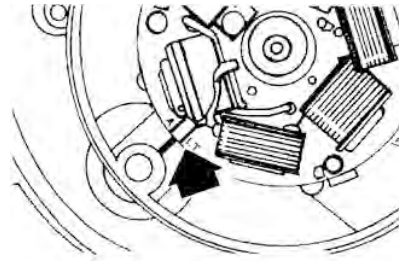

Flywheel and starting

Removing the starter motor

– Remove the two screws and detach the drive box from the starter motor.

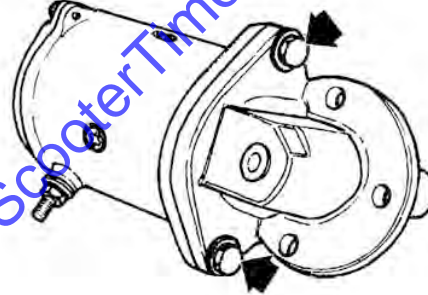

– With the aid of a hacksaw, abrade the pinion head ring.
– Using two screwdrivers, detach the cap.

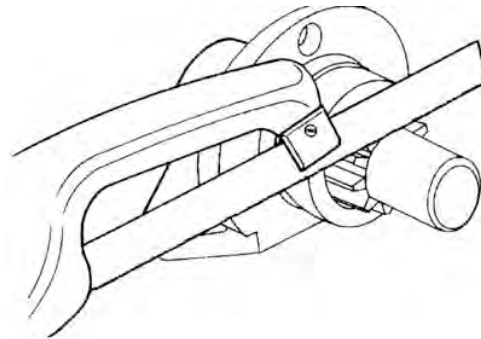

– Remove the retaining ring shown by the arrow in the figure and remove the pinion components.

WARNING

THE PACKING ON THE MATING SURFACE MUST ALWAYS BE REPLACED WITH A NEW ONE, USING «LOCTITE».

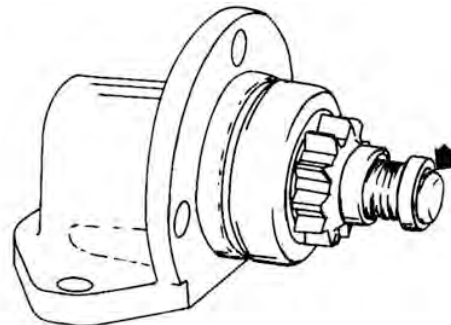

- Using pliers for internal split rings, remove the retaining ring shown.
- Lift the assembly by the end of the shaft and remove the shaft by hitting the housing with a mallet.

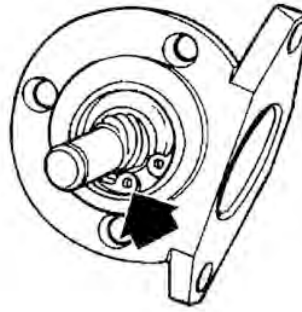

- The removal of the bearing may be carried out by pushing in the direction shown in the figure. This will also result in the removal of the drive gear.
- In the event that the bearing remains on drive gear, use the special extractor.
- After heating the drive gear with the air heater, refit the drive shaft with all the components previously removed.
- Refit the remaining components following the above operations in the reverse order.



Specific tooling

001467Y Bell

001467y021 11 mm bearing clip

020151Y Air heater "METABO HG 1500/2"

020150Y Support for air heater "METABO HG 1500/2"

- Position a new cap onto the pinion and round the edges using the special tool to safely lock the assembly in a vice.
- Rotate the assembly by a quarter turn and proceed by rounding the remaining section of the caps circumference.

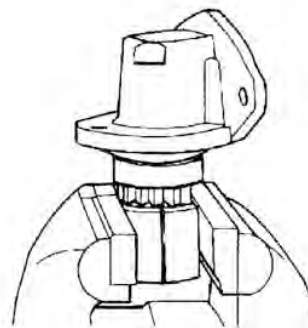

Specific tooling

020057Y Calking tool

- After removing the rear cover, release the brush clips connected to the magnetic fields.
- Remove the brush plate. Detach the old brushes and weld a new set of brushes, hence replace the brush plate.

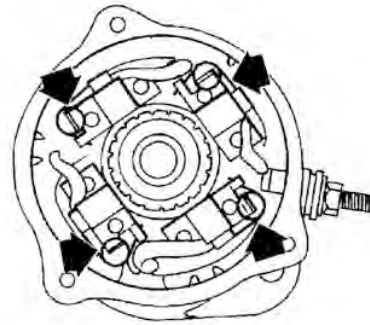

- After removing the rear cover, detach the drive gear retaining pin and remove the gear.
- Refit the assembly components in the reverse order.

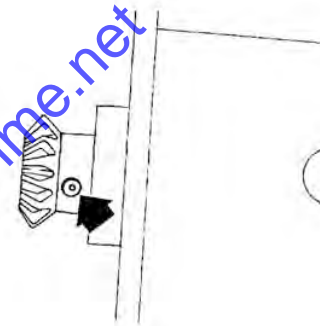

Removing the flywheel magneto

- Retain the flywheel using the special tool, hence remove the lock nut.

Specific tooling

020095Y Flywheel retaining tool

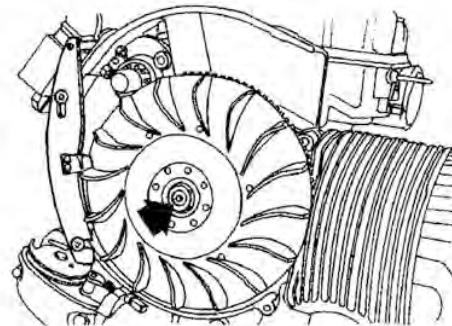

- Remove the flywheel retaining tool.
- Extract the flywheel using the special extractor.

Specific tooling

008564Y Flywheel extractor

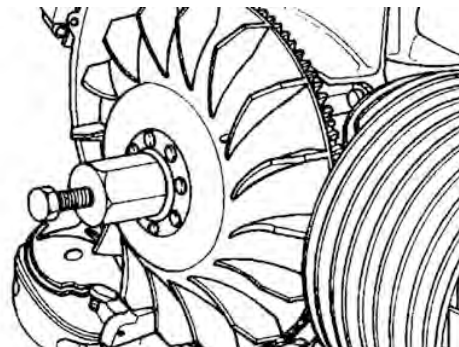

Refitting the flywheel magneto

- Refit the components following above operations in the reverse order.
- After refitting the flywheel, apply grease on the thread.

Recommended products

Grease Z2 Product description

Grease Z2

Locking torques (N*m)

Flywheel fixing nut $60 \div 65$

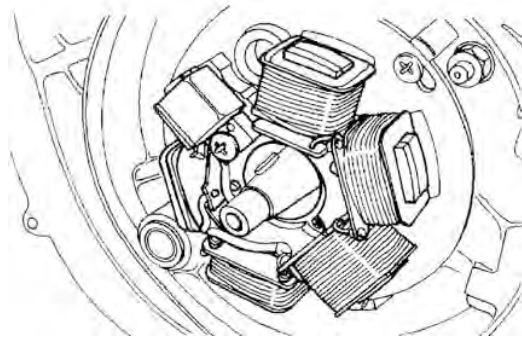

Cylinder assy. and timing system

Removing the cylinder head

- Loosen the four nuts and remove the cylinder head.

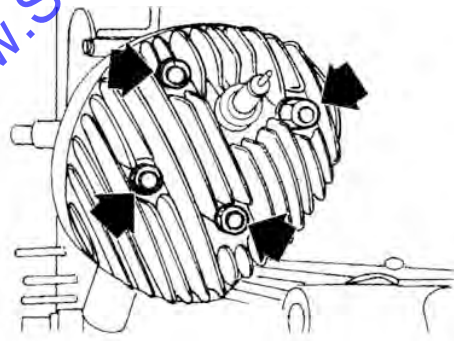

Removing the cylinder - piston assy.

After removing the cylinder detach the wrist pin retaining rings and hence remove the piston.

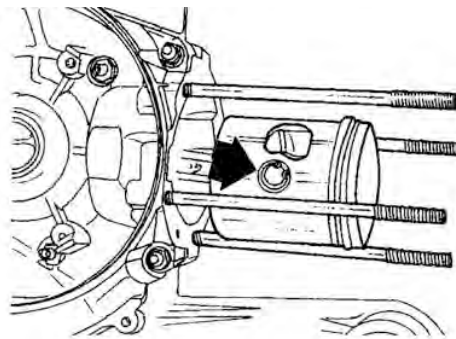

Inspecting the small end

– Always fit a roller cage of the type prescribed in the assembly clearance tables.

– The arrow in the figure shows the location of the connecting rod's identification marking.

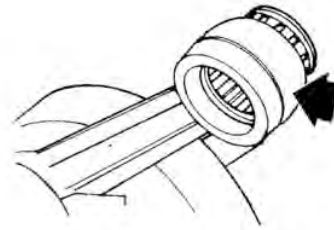

Refitting the cylinder

– Refit the cylinder assembly components following the removal procedure in the reverse order, paying particular attention to positioning the piston with the arrow marking on the crown pointing toward the exhaust port.

Locking torques (N*m)

Head fixing nuts $16 \div 26$

Crankcase - crankshaft

Splitting the crankcase halves

– Remove the twelve fasteners and split the two crankcase halves carefully using a plastic or hard rubber mallet.

CAUTION

WITH A RUBBER BAND TIE THE CONNECTING ROD TO THE TWO STUDS ON THE CLUTCH-SIDE, SO TO AVOID ANY ACCIDENTAL DAMAGE DURING THIS PHASE AND THE FOLLOWING ONES.

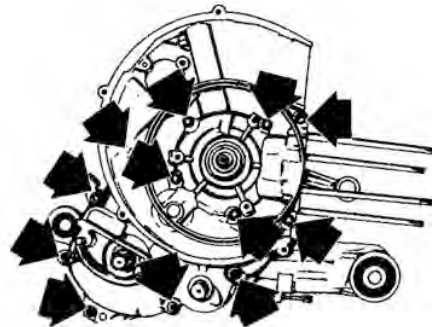

Removing the crankshaft

– Install the special tool as shown and extract the crankshaft.

Specific tooling

008886Y Crankshaft extractor

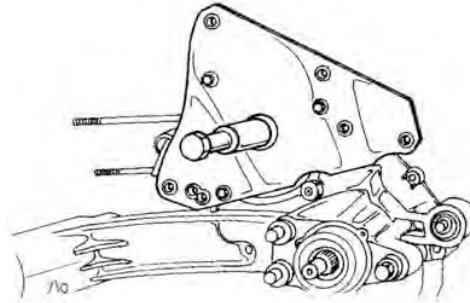

Removing the crankshaft bearings

- After removing the oil seal, using pliers for internal split rings, remove the bearing retaining ring shown.
- From the side opposite that shown in the figure and with the aid of a flat head puncher, extract the bearing.

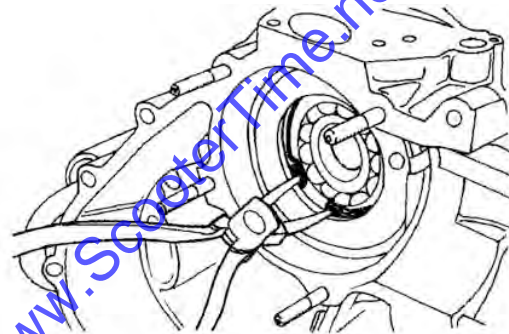

- Using the special extractor, remove the roller bearing from the crankshaft.

Specific tooling

004499y Bearing extractor

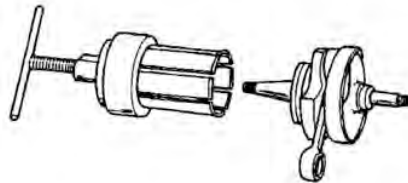

- Using the special extractor, remove the roller bearing from the crankcase.

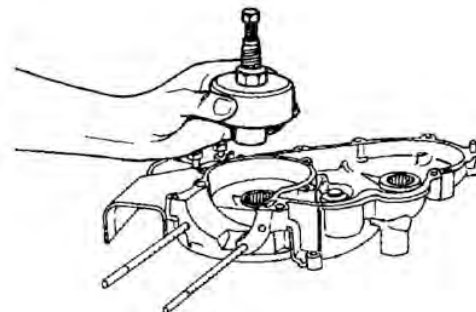

Refitting the crankshaft bearings

- Heat the bearing housing with the air heater positioned onto its support.
- After heating the crankcase, position the bearing using a length of tube pushing directly on the bearing's outer ring.
- Position the bearing's retaining ring, hence proceed by refitting the sealing ring.

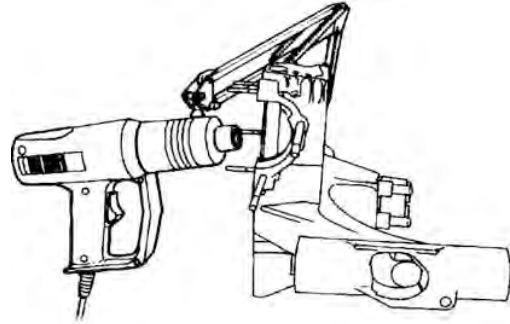

Specific tooling

020151Y Air heater "METABO HG 1500/2"

020150Y Support for air heater "METABO HG 1500/2"

- Heat up the crankcase, as already done for the clutch-side half-crankcase, focusing exclusively on the bearing housing.
- Position the bearing using a length of tube pushing directly on the bearing's outer ring.

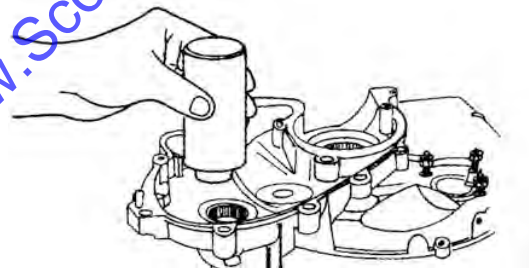

- Position the crankshaft onto the special support.
- Install the special spacer as shown in the figure and, using a length of tube of adequate diameter, push the bearing until the inner ring (heated up in oil at 248°F or 120°C) comes into contact with the spacer.
- Once the assembly is completed, remove the spacer.

Specific tooling

020265y Bearing fitting stand

060007Y Crankcase bearing spacer

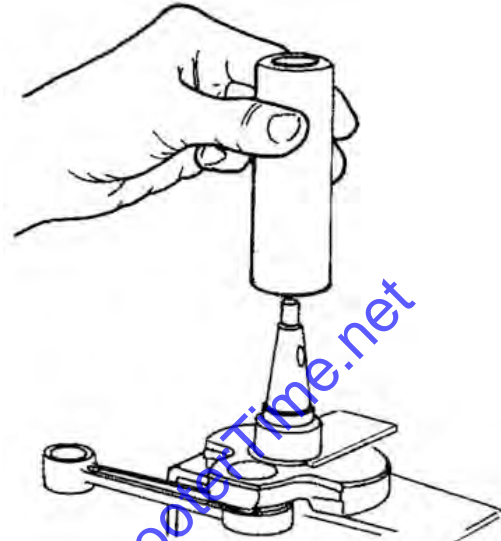

Lubrication

Conceptual diagrams

Automatic fuel mixer

The system is fed by oil contained in a separate tank.

The vehicle is equipped with two distinct tanks, each with individual hoses, for fuel and lubricant.

The fuel tank must be filled with petrol, no petrol-oil mixture of any kind, while for the lubricant tank Selenia Hi Scooter 2T oil should be used. The oil level may be checked through the transparent tube (see figure, 3) protruding from the tank.

Fuel is fed to the carburetor by gravity; oil is supplied through pump «p» whose stroke is controlled by the radial position of a shoe, on the inclined plane of the pump, driven by the throttle cable via a lever.

This means that for any given position of the throttle twist-grip the location of the shoe varies, thus varying the pump stroke hence suggesting that the oil mass flow is a function of both engine speed and throttle opening.

Important: whenever the mixer device has been removed, overhauled or refitted, there may be no oil inside the ducts.

To allow the mixer to safely fill these ducts with oil, it is suggested that the fuel tank (1 in the figure) is

first refilled with approx. 3 l of mixture containing 2% of SELENIA HI SCOOTER 2T oil. Once this first quantitative has been exhausted, any further refill must obviously consist of petrol only. The pump assembly constitutes, essentially, of a pumping element and its sliding housing, and is driven by a gear transmission (crankshaft/mixer shaft ratio: 1/85). The pumping element "P" is also provided, on its shaft, with a flatten surface which, because of the rotation, alternately opens and closes the oil inlet (5) and outlet (6) ducts, with the latter being equipped with a valve consisting of a sphere and spring. By such means the pump alternately performs the two phases of oil intake (A in the figure) and supply to the fuel diffuser (8 in the figure), where the fuel mixture is formed and fed into the engine.

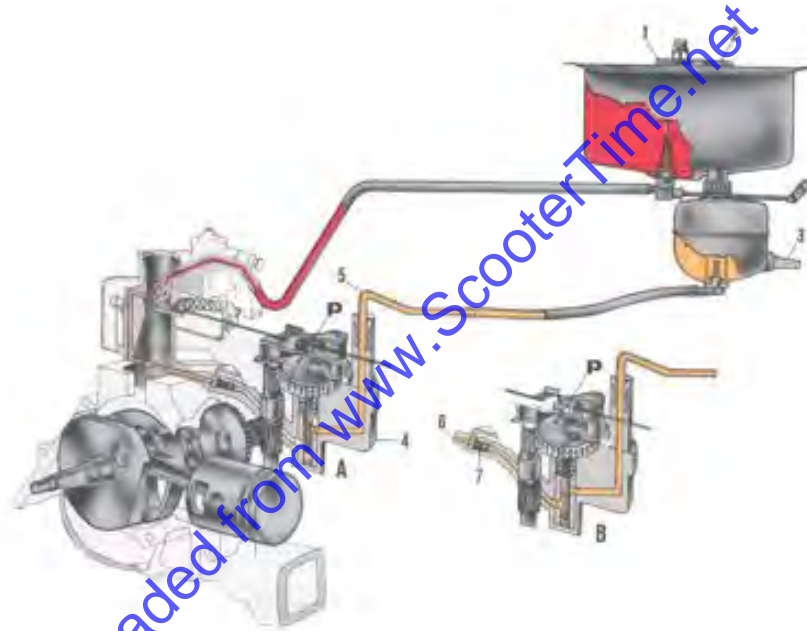

CONCEPTUAL DIAGRAMS

Specification	Desc./Quantity
Fuel tank filler cap	
Oil tank filler cap	
Oil level gauge	
SEPARATE LUBRICATION device box	
Oil inlet hose	
Oil outlet hose	
Oil outlet valve	
A	Inlet phase
B	Outlet phase

Oil pump

- Remove the carburettor box.
- Remove the mixer drive shaft from its housing.

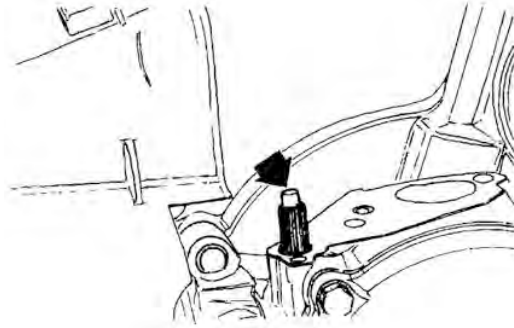

-
- Remove the 3 fixing screws and the mixer cover with the lever.

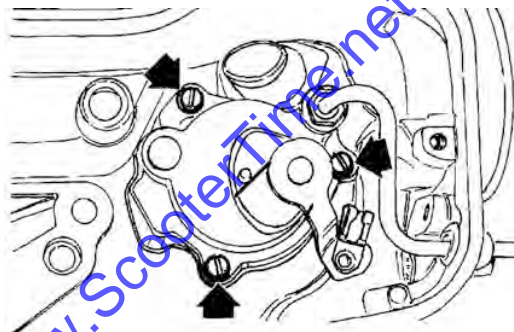

-
- Remove the mixer pumping element.

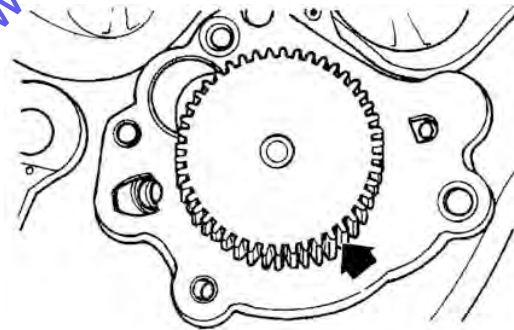

-
- Remove the mixer fixing screw and then use pliers for internal split rings to remove the mixer body.

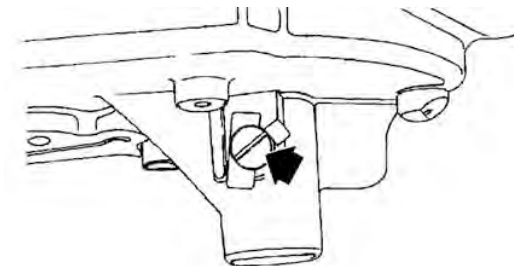

-
- Refit the components following the removal pro-
-

cedure in the reverse order, paying attention in positioning the pump body correctly in its housing, so to be able to easily insert the retaining screw.

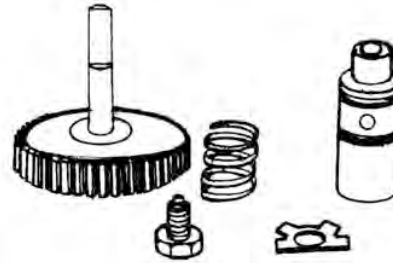

See also

[Removing the carburettor](#)

Fuel supply

Removing the carburettor

– Remove the two fixing screws and the carburetor cover.

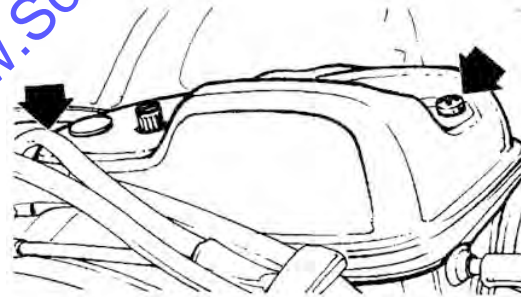

– Remove the fasteners and the air filter.

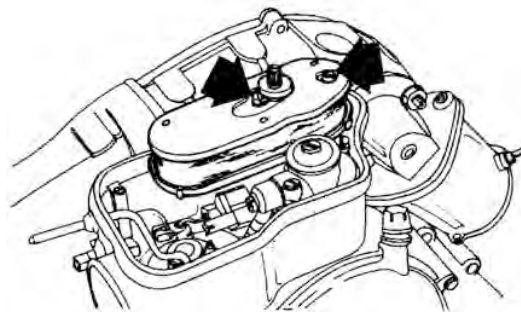

– After removing the air filter, loosen the two 8mm Allen screws and hence remove the carburetor.

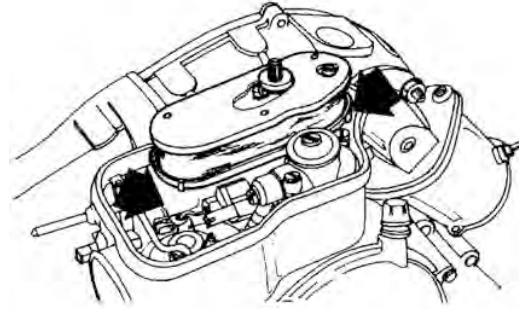

- Loosen the fixing screw and remove the carburetor body.

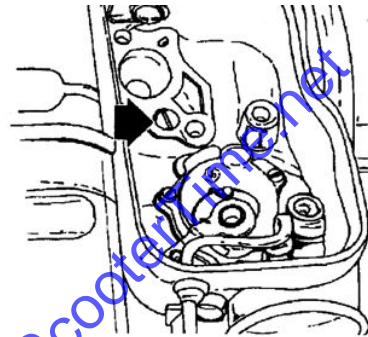

- Remove the main and idle jets and blow with compressed air.

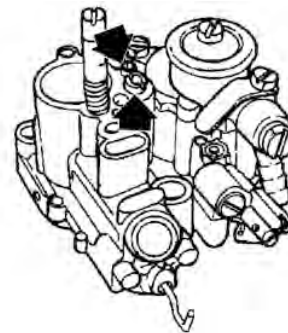

- Loosen the fixing screw and remove the float bowl.

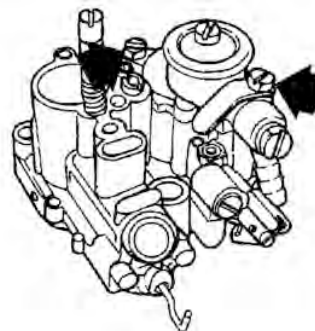

- Remove the starter jet and blow with compressed air.

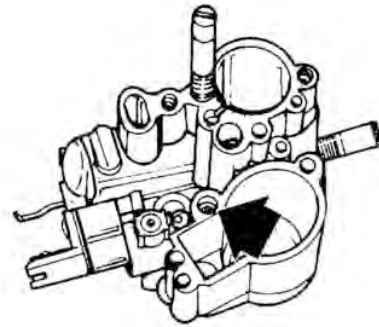

- Remove the float pin to release the float, and hence the conical needle.

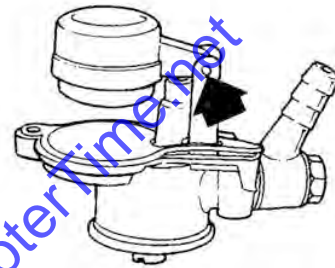

- Check the starter choke valve; replace if worn

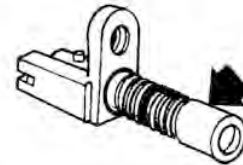

Refitting the carburettor

- Refit the components replacing all seals.

WARNING

PETROL IS HIGHLY EXPLOSIVE. ALWAYS FIT NEW SEALS AND GASKETS TO PREVENT LEAKAGE.

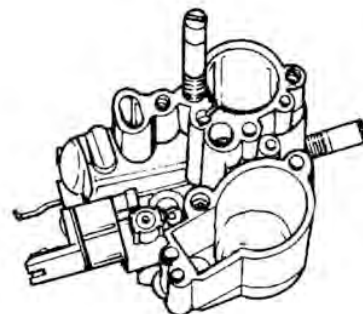

Manual Gear Shifter

Remove the fasteners and the gear shifter.

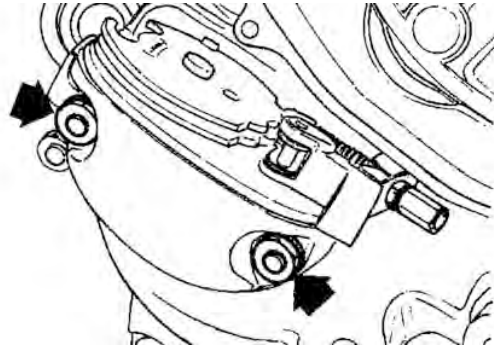

From the side opposite to that shown in the figure and with the aid of a puncher, remove the conical pin and extract the gear shifting lever.

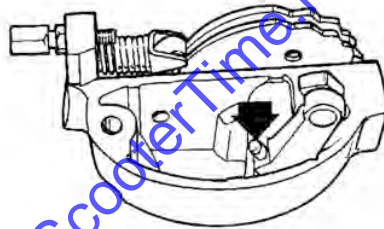

- Split the two half-crankcases.
- Using pliers for external split rings, remove the retaining ring and extract the gears.

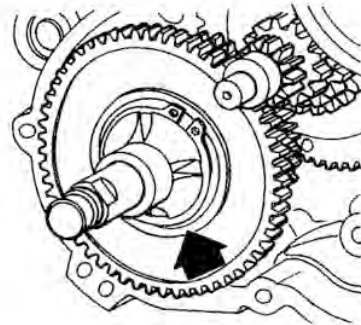

- Using a plastic mallet, remove the shaft.

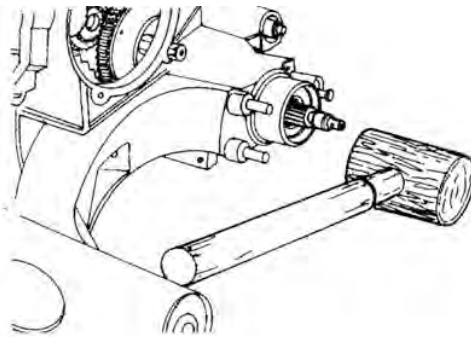

- Remove the multiple gear shaft lock nut.

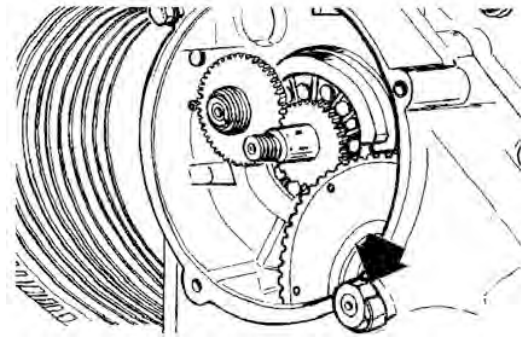

- Remove the multiple gear shaft using a mallet from the side opposite to that shown in the figure. Do not let the 21 rollers composing the bearing fall onto the ground.

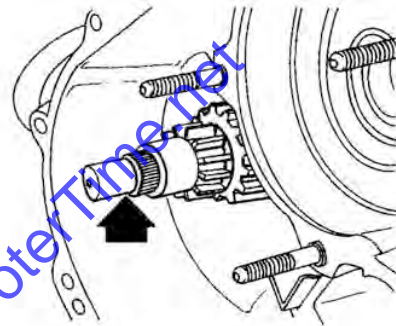

- After removing the internal oil seal and the external dust cover, remove the bearing retaining ring through the use of internal split ring pliers.
- Extract the roller bearing using a flat head puncher from the side opposite to that shown in the figure.

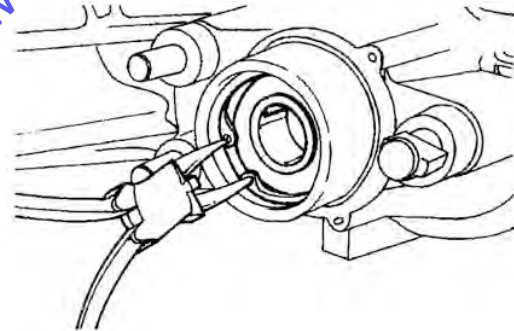

- After removing the retaining washer shown in the figure, remove the fastener underneath it, hence extract the even tension gear.
- Remove the rivet head and replace any faulty component.
- Refit the components using new rivets.

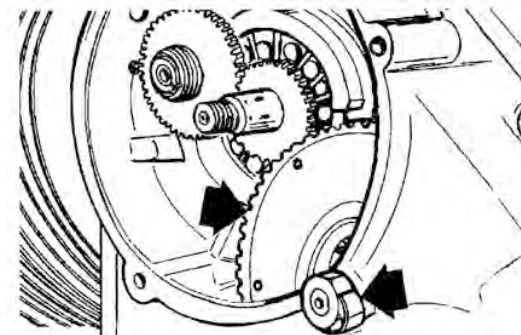

- Replace the trunnion if worn.

CAUTION

THE TRUNNION BUSHING HAS A LHS THREAD.

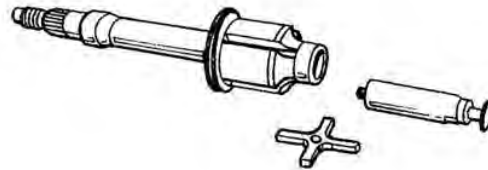
Locking torques (N*m)**Gear-box trunnion 15 ÷ 18**

- Refit the trunnion «A» onto the gear shifter shaft «B» and tighten it to the prescribed torque (LHS thread).
- Prepare a tool «D» as shown in the figure and insert it into the groove machined on the shaft.
- Align the tool's protrusion «C» with the edge «F» of the bushing to be rounded.
- Using a hammer and a length of tube (internal diameter 17.5 mm), round the threaded end of the bushing on the trunnion.

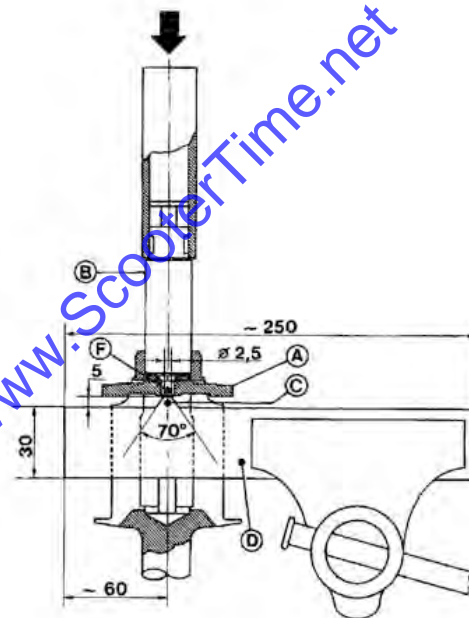

- Install the multiple gear onto its housing carefully positioning the 21 rollers, using the recommended grease to keep them in place during the reassembly.
- With the refitting operation concluded, tighten the shaft lock nut to the prescribed torque.

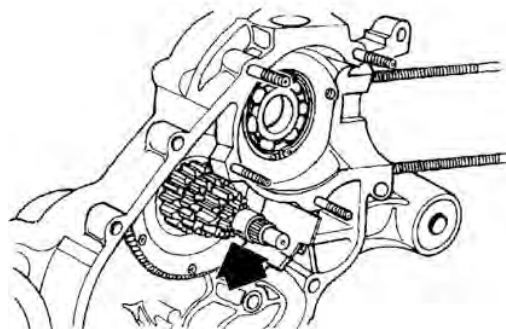
**Recommended products****JOTA 3 FS Speedometer transmission**

Lithium soap grease NLGI 33

Locking torques (N*m)**Multi-gear pinion nut 30 ÷ 35**

- Before proceeding by refitting the shifter shaft, it is necessary to check the axial play of the gear assembly.

- Install the gears onto the shaft and check the end play with the special feeler gauge.



Specific tooling

060824Y Inspection probe

Characteristic

Axial play

0,20 ÷ 0,40 mm

- Using the special tool, proceed by removing the gear shaft.

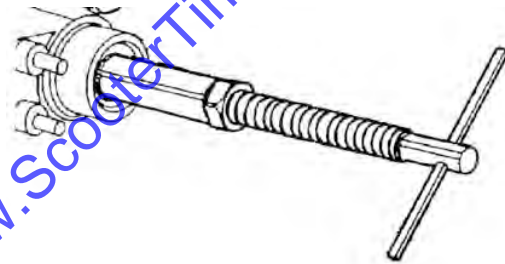

Specific tooling

008119y009 Tube (shaft fitting tool)

See also

[Splitting the crankcase halves](#)

Clutch

- Remove the 3 fixing screws and the clutch cover.

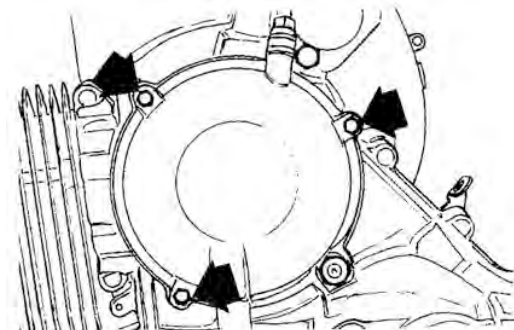

- With the aid of a screwdriver, remove the balance screw.

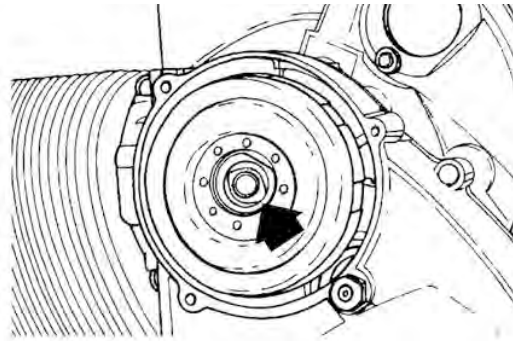

- Restrain the clutch using the special tool, as shown in the figure, then remove the locknut and the clutch assembly.

CAUTION

DURING THE OPERATIONS OF REMOVAL, DO NOT LET THE WOODRUFF KEY FALL INSIDE THE ENGINE.

Specific tooling

001729Y Clutch retaining tool

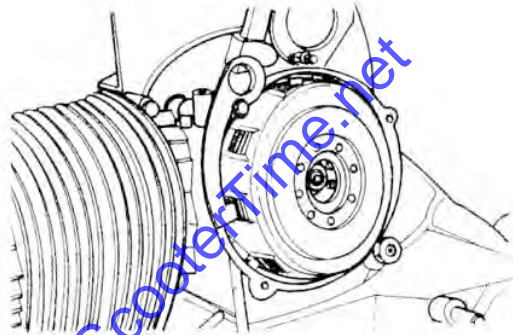

- Remove the mixer drive gear from its housing.

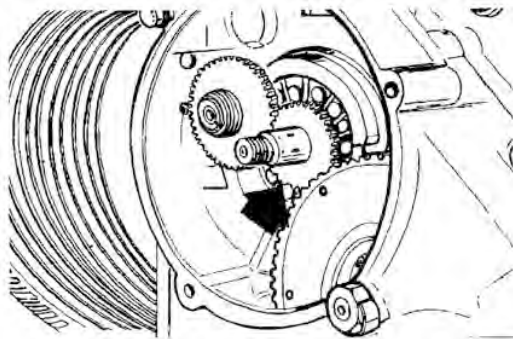

- Using the special tool, remove the clutch discs.

Specific tooling

020322Y Clutch removing/fitting tool

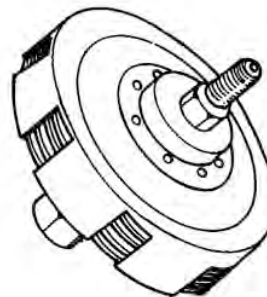

- Check the conditions of all components and the

camber of the metal discs. A camber smaller than the prescribed one may cause slippage.

- Refit the clutch assembly components inverting the order followed for the disassembly.

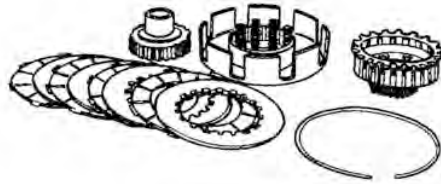

- Place the mixer drive gear with the rounded edge facing the crankcase bearing.

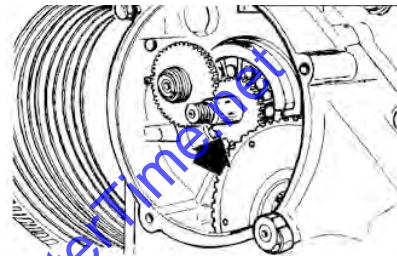

- Correctly position the woodruff key inside its housing.

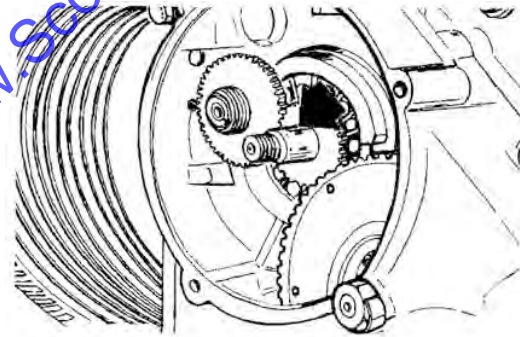

- Refit the clutch assembly onto the engine and tighten the locknut using the special retainer.
- Refit the remaining components in following the procedures carried out from their removal in the reverse order.

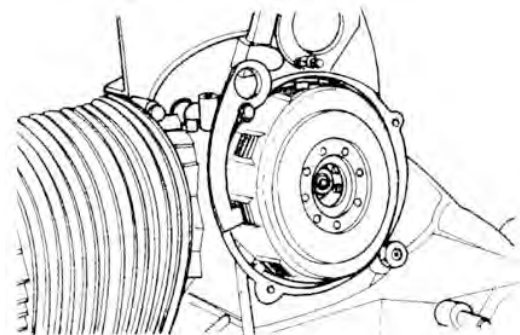

Specific tooling

001729Y Clutch retaining tool

Locking torques (N*m)

Clutch assy. fixing nut 40 ÷ 45

Downloaded from www.ScooterTime.net

INDEX OF TOPICS

SUSPENSIONS

SUSP

Downloaded from www.ScooterTime.net

Front

Front wheel hub overhaul

After removing the front brake calliper, remove the plastic cap shown in the figure.

Remove the pin and the locknut.

It is now possible to remove the wheel axle nut.

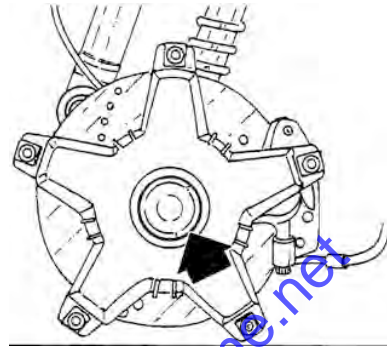

After removing the split ring on the outer side of the wheel hub, and the seal ring, remove the bearing using a length of pipe of adequate diameter and a mallet, as shown in the figure. Follow the same procedure to remove the roller cage on the opposite side.

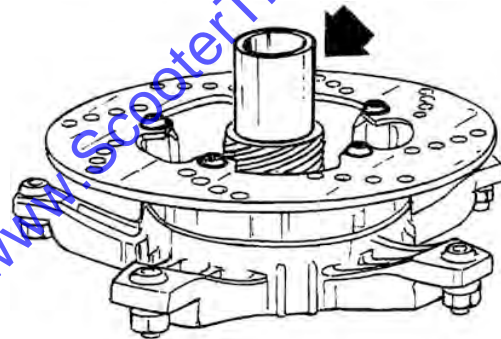

Handlebar

Removal

Remove the 2 rear view mirrors and their fixing ring nuts. Remove the handlebar cover as described in the «Bodywork» chapter and the speedometer.

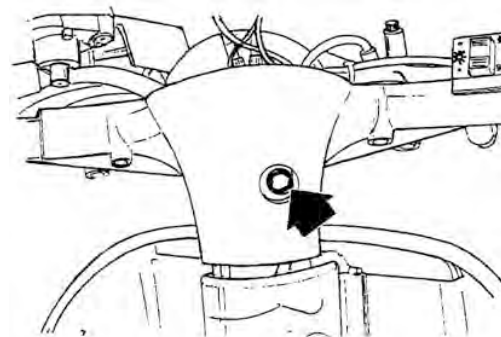

Refitting

Upon reassembly, tighten to the prescribed

torque.

N.B.

* Safety tightenings

IN ORDER TO ENSURE THE CORRECT TIGHTENING TORQUE, LUBRICATE NUTS BEFORE ASSEMBLY.

Locking torques (N*m)

Handlebar fixing screw* 30+44

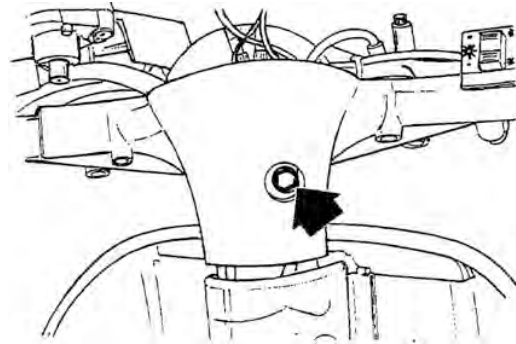

Steering column

Removal

– After removing the top housing, lean the vehicle on one side and extract the steering column, making sure of having removed the brake calliper.

Specific tooling

020055Y Steering tube ring nut spanner

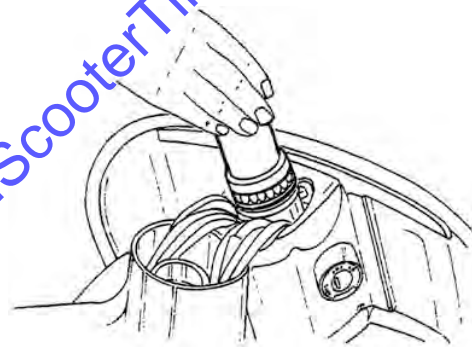

Overhaul

The steering-front suspension assembly overhaul operation, described here, implies essentially the substitution of the components (pin-roller bushing assembly, sealing rings and dust covers) linking the steering column to the front swing arm assy.

N.B.

BEFORE PROCEEDING WITH THE OVERHAUL OPERATION ENSURE THE STEERING COLUMN AND THE HUB ARE IN OPTIMAL CONDITIONS: THIS IS THE ONLY CASE IN WHICH THE OVERHAUL OPERATION MAY BE PERFORMED.

NOTE THAT IF THE STEERING COLUMN HAS BEEN DEFORMED IN ANY WAY IT MUST BE REPLACED WITH A NEW ONE.

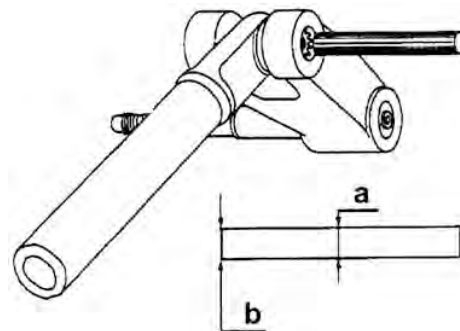

a = puncher \varnothing 12

b = Sharp-edged end

Use a puncher with the dimensions indicated in the figure; using a mallet, squash the impaction washer and extract it.

Repeat this operation from the side opposite to that shown in the figure, to remove the second washer.

Apply the tool with part 1 as shown in the figure and act upon the handle until the contemporary extraction of both pin and needle cage is obtained.

By expelling these two components, the swing-arm is completely detached from the steering column.

To expel the second needle cage, install part 2 onto the special tool, instead of 1, and operate from the side opposite to that shown in the figure.

N.B.

THE OPERATION DESCRIBED ABOVE RESULTS IN THE DESTRUCTION OF THE NEEDLE CAGES FOLLOWING THEIR EXTRACTION. UPON REFITTING IT IS THEREFORE NECESSARY TO USE NEW NEEDLE CAGES, AS WELL AS NEW PIN, SEALING RINGS AND DUST COVERS.

Specific tooling

020021y Front suspension overhaul kit

Attach the swing arm to the steering column using the guide pin.

– With the tool fitted with part 3 on its shaft, and part 4 at its lower end, insert the pin, greased with the **(Molykete powder)** based grease, onto the swing-arm and act upon the tool's handle as far as part 3 will go.

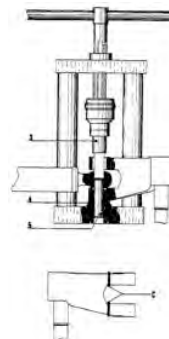
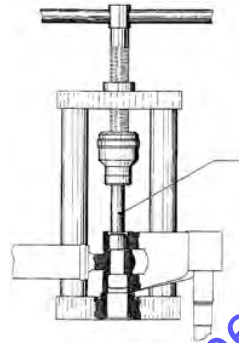

Once the pin is fitted, insert the two spacers with aid of a mallet.

N.B.

BEFORE PROCEEDING WITH THE PROCESS ABOVE, FIT THE TWO DUST COVER RINGS ONTO THE SWING-ARM AS SHOWN IN THE DETAILED VIEW.

Specific tooling

020021y Front suspension overhaul kit

Recommended products

TUTELA MRM2 Grease for driven pulley bushing and mobile driven pulley seat

Bisulphide soap grease with Molybdenum NLGI2

Insert the sealing ring onto the pin and the roller bushing fitted with the securing washer.

- Remove the tool and part 5 (guide), partially expelled during the previous pin assembling phase, leaving part 4 in place.
- Replace part 3 with part 16, again on the shaft.
- Acting upon the handle, push the securing washer - roller bushing - sealing ring assembly as far as part 16 will go.
- Repeat the above operation, using the tool fitted with parts 16 and 22 instead of part 4, to fit the assembly onto the opposite side.

WARNING

BEFORE CARRYING OUT THE ABOVE OPERATIONS, IT IS NECESSARY TO IMMERSE THE SEALING RINGS IN MINERAL OIL AND FILL THE ROLLER BUSHINGS HALFWAY WITH GREASE, AFTER WASHING THEM IN PURE PETROL.

Specific tooling

020021y Front suspension overhaul kit

Recommended products

JOTA 3 FS Speedometer transmission

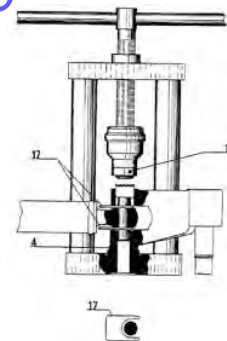

Lithium soap grease NLGI 33

- Use the tool fitted with part 20 onto its shaft and part 21 on its lower surface, as shown in the figure.
- Acting upon the handle, push the roller bushing in until it touches the edge of the pin.
- Use the tool fitted with parts 3 and 4, to fit the pin, and twist the handle until the washers secure on the swing-arm.
- At this point, remove the two spacers (part 17 and 16) and, after completely filling the region between the roller bushings, steering column and swing-arm with grease, move the dust covers and locate them in the above area.
- The securing operation for the washers concludes the assembling operation for the front suspension.

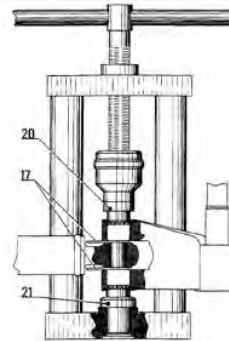

Recommended products

JOTA 3 FS Speedometer transmission

Lithium soap grease NLGI 33

To remove the bearing housings from the frame use the special tool shown in the figure.

Specific tooling

020004Y Drift for removing thrust rings from steering head tube



-
- Using the special tool remove the bearing and dust ring housings from the steering column as shown in the picture.
 - Proceed with mallet hits.
-

Specific tooling

020004Y Drift for removing thrust rings from steering head tube



– Using the special tool, refit the dust ring and the bearing housing onto the steering column and push them as far as they go.

Specific tooling

006029y Drift for fitting thrust ring seats on steering tube

**Refitting**

- Grease bearings and housings.
- Tighten to the prescribed torque and rotate the spanner in an anti-clockwise direction by 80°-90°.

Specific tooling

020055Y Steering tube ring nut spanner

Recommended products

SYSTEM TW 249 AREXONS Grease (brake level, throttle twistgrip, gaer)

Calcium complex soap grease NLGI 1-2

Locking torques (N*m)

Top steering housing 6÷7 (hence loosen by 80° - 90°) Upper steering ring nut 5÷6

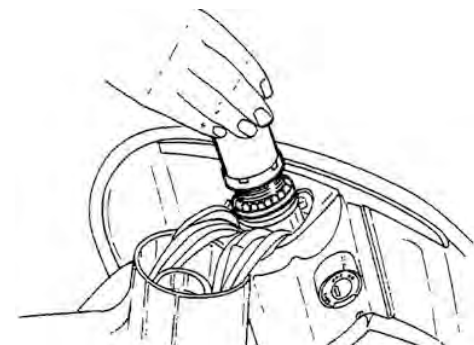
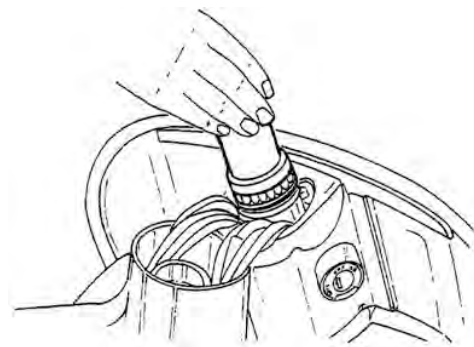
**Front shock absorber**

Removal

Remove the 2 fixings shown in the figure and the 2 fasteners on the shock-absorber support bracket located on the steering column.

Free the shock-absorber from the support bracket removing the top fixing.

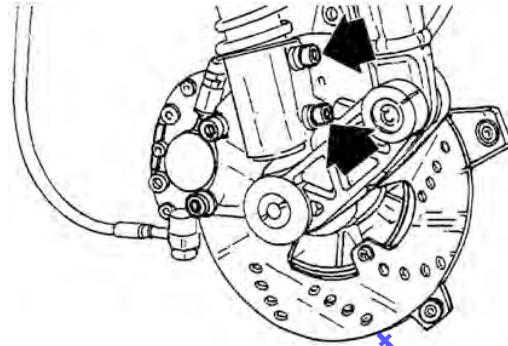

Shock-absorber - calliper bracket

Removal

Remove the split ring shown in the figure.

Remove the two shock-absorber fixing screw and the odo/speedometer cable holder.

Extract the bracket from the axle using a rubber mallet.

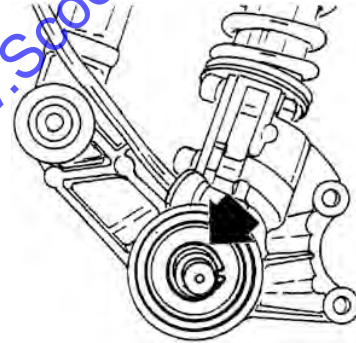

Overhaul

In the event of grease leaks through the wheel hub, the cause may be found in the sealing ring fitted onto the calliper bracket.

After removing the wheel hub, extract the ring shown in the figure and replace it with a new one.

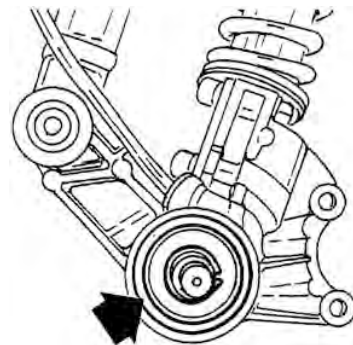

Rear

Removing the rear wheel

- After removing the spare wheel, remove the three fasteners shown in the figure.
- Remove the rear wheel by loosening the five fixing screws.

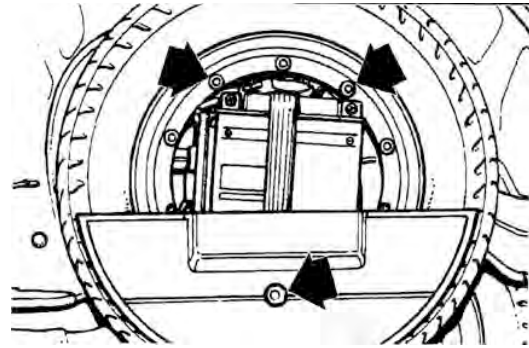

Refitting the rear wheel

- When refitting the rear wheel, tighten all fasteners at the prescribed torque following a crosswise sequence.

Locking torques (N*m)

Rim - hub fixing nuts (front-rear) 20 ÷ 27

Shock absorbers

Removal

For the rear shock-absorber replacement it is necessary to remove the engine - shock-absorber fixing bolt as shown in the figure.

Remove the gasoline and oil tanks, then remove the shock absorber upper fixing in the underseat compartment housing.

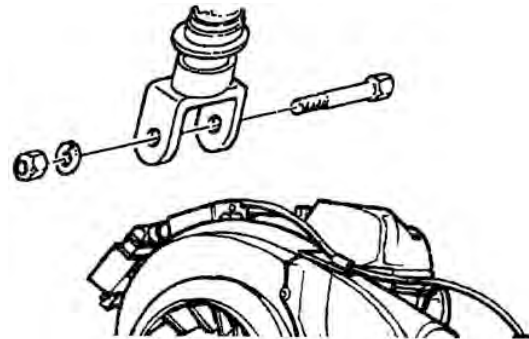

Centre-stand

Detach the return spring from the centre stand, remove the 4 fasteners shown in the figure.

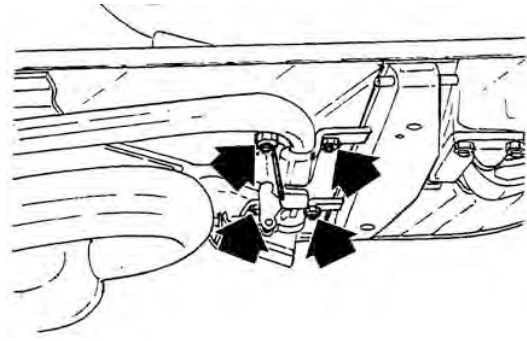

Downloaded from www.ScooterTime.net

INDEX OF TOPICS

BRAKING SYSTEM

BRAK SYS

Downloaded from www.ScooterTime.net

Front brake calliper

Removal

- Detach the brake hose from the calliper using a container to collect the fluid.
- Remove the fasteners shown in the figure.

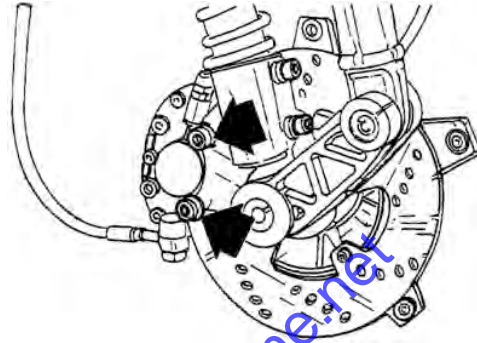

Refitting

- When refitting, tighten the nuts to the prescribed torque.
- Bleed the system.

N.B.

* Safety tightenings

IN ORDER TO ENSURE THE CORRECT TIGHTENING TORQUE, LUBRICATE NUTS BEFORE ASSEMBLY.

Locking torques (N*m)

Pipe - calliper fitting 15÷25 Calliper fixing screw* 20÷25

Front brake disc

Removal

- Remove the rear wheel by loosening the 5 fasteners.
- Remove the wheel hub.
- Loosen the 5 disc fasteners.

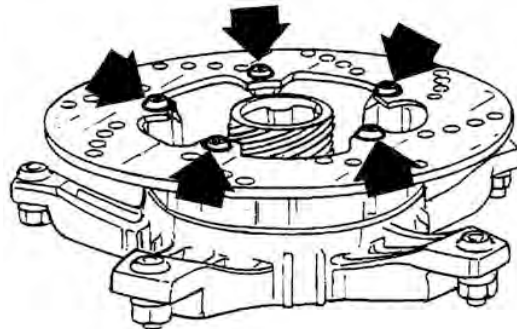

Refitting

- When refitting, correctly position the disc, observing the direction of rotation (see figure) and apply medium thread-lock.

N.B.

* Safety tightenings

IN ORDER TO ENSURE THE CORRECT TIGHTENING TORQUE, LUBRICATE NUTS BEFORE ASSEMBLY.

Recommended products

Loctite 243 Thread-Brake

Medium Loctite Thread-Brake 243

Locking torques (N*m)

Disc fixing screw* 5÷6

Disc Inspection

- Remove the wheel and check any possible disc's out-of-plane. The measured value must be less than 0.1 mm. If higher, replace the disc and repeat the check.
- If the problem is not solved check and, if necessary, replace the wheel hub.

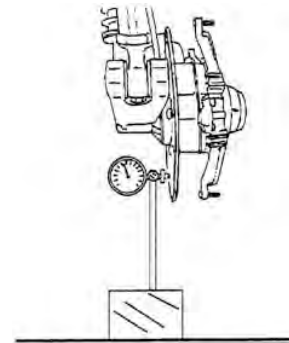

Specific tooling

020335Y Magnetic stand and comparator

Front brake pads

Removal

- To facilitate this operation it is suggested that the front wheel is removed, remove the plastic cap and apply leverage with a screwdriver.
- Remove the external split ring from the pin, the spring and the pads themselves.
- The pads must be replaced if the thickness of the working material is less than 1.5 mm.

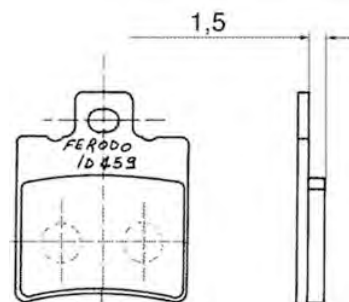

Refitting

- When refitting, operate in the opposite way, paying attention in positioning the spring with the arrow pointing upwards.

Fill

Front

- Once the bleeding valve is shut, top-up the circuit using fresh brake fluid.
- Loosen the bleed screw.
- Connect the special tool's tube to the bleed hole. To bleed the system, constantly refill the reservoir, while pumping out air with the Mityvac, until all air has been removed from the circuit, i.e. only fluid is pumped out of the system.
- Tighten the bleed screw.

N.B.

IF YOU FIND YOU CANNOT ELIMINATE THE AIR, EXAMINE ALL THE UNIONS IN THE CIRCUIT. IF YOU DON'T FIND ANY LEAKS, SEEK THE FAULT IN THE VARIOUS SEALS ON THE MASTER CYLINDER AND BRAKE CALLIPER PISTONS.

CAUTION

DURING THIS PROCEDURE THE VEHICLE MUST BE ON THE STAND ON A LEVEL AND HORIZONTAL FLOOR.

N.B.

DURING THE BLEED PROCEDURE, CHECK THE FLUID LEVEL IN THE MASTER CYLINDER RESERVOIR FREQUENTLY TO PREVENT THE RISK OF AIR ENTERING THE CIRCUIT THROUGH THE MASTER CYLINDER.

WARNING

THE BRAKE FLUID IS HYGROSCOPIC, I.E. IT ABSORBS HUMIDITY FROM THE AIR. IF THE HUMIDITY LEVEL IN THE FLUID EXCEEDS A GIVEN VALUE, THE BRAKING PERFORMANCES MAY SERIOUSLY DETERIORATE. IT IS THEREFORE RECOMMENDED THAT FRESH FLUID IS TAKEN FROM NEW CONTAINERS. IN NORMAL CLIMATIC CONDITIONS, THE FLUID SHOULD BE REPLACED EVERY TWO YEARS. IF THE BRAKES ARE HIGHLY STRESSED, INCREASE THE FREQUENCY WITH WHICH THE FLUID IS REPLACED.

CAUTION

DURING THE OPERATION, OIL MAY LEAK BETWEEN THE BLEEDER SCREW AND THE SEAT ON THE CALIPER. IN THAT CASE, CAREFULLY DRY THE CALIPER AND DEGREASE THE DISC.

Recommended products

TUTELA TOP 4 Brake fluid

Synthetic fluid SAE J1703, NHTSA 116 DOT 4, ISO 4925

With the operation concluded, tighten the bleed screw to the prescribed torque.

Specific tooling

020329Y Pump MITYVAC

Locking torques (N*m)

Oil draining screw 10÷12

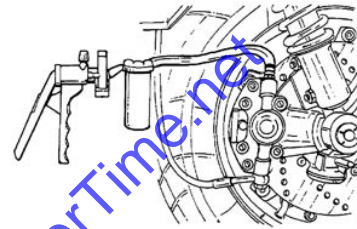
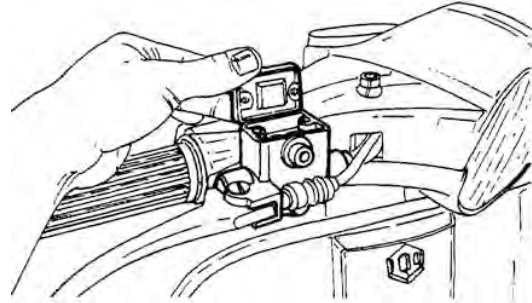

Front brake pump

Removal

- Loosen the two fasteners shown in the figure.
- Detach the hose, collecting the fluid inside a container.

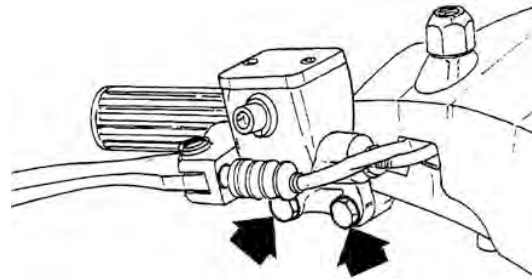

Refitting

- For refitting, perform the operation in the reverse order.
- Tighten the pipe to the prescribed torque and bleed the circuit.

Locking torques (N*m)

Reservoir - pipe fitting 8÷12

Rear drum brake

- Remove the rear wheel.
- Straighten the splint pin and remove the lock

nut.

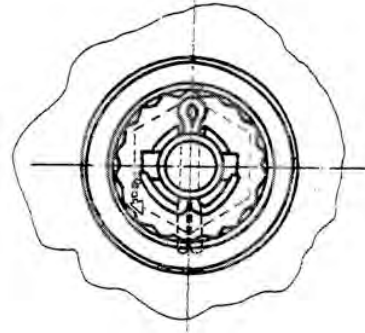

– After removing the hub, proceed as follows:

1. Remove the shoe spring using the special pliers.
2. Remove the two retainers shown in the figure.
3. Remove the shoes using a lever.
4. Fit the new shoes with the aid of a mallet.
5. Attach the return spring using the special pliers.

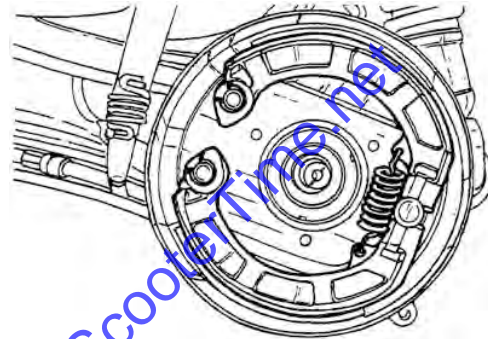

Specific tooling

020325y Pliers for brake-shoe springs

– Refit the components following the removal procedures in the reverse order, tightening the wheel nut to the prescribed torque.

WARNING

USE A NEW SPLIT PIN

WARNING

BEND OVER THE SPLIT PIN ENDS AS SHOWN IN ORDER TO ELIMINATE PLAY BETWEEN THE CAP AND WHEEL SPINDLE.

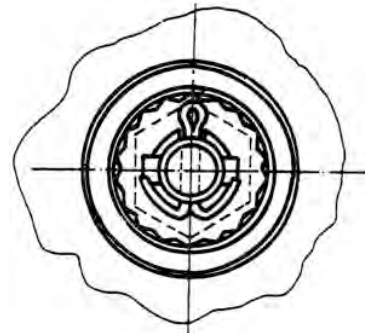

Locking torques (N*m)

Wheel axle nut 90÷110

Rear Brake Pedal

After loosening the brake fixing on the rear wheel, remove the 3 fasteners indicate in the figure.

Remove the rubber from the pedal and detach the electrical wiring.

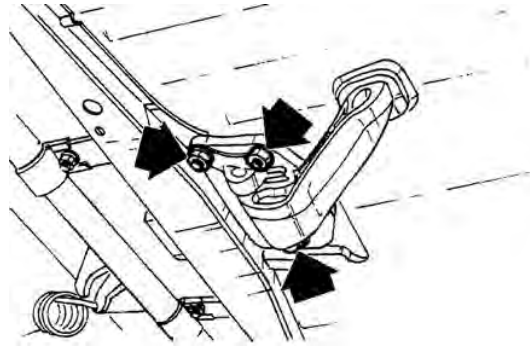

After this operation it is possible to remove the fore brake cable retainer, removing the splint pin and its pin.

It is also possible to replace the stop switch by acting upon its fixing.

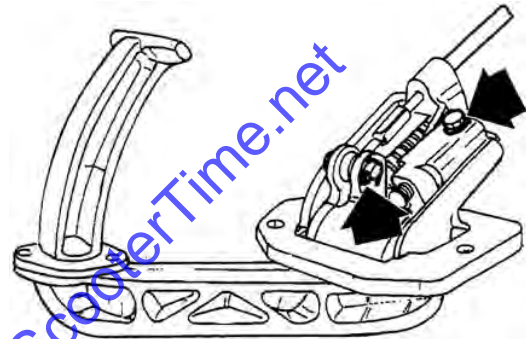

Downloaded from www.ScooterTime.net

INDEX OF TOPICS

CHASSIS

CHAS

Downloaded from www.ScooterTime.net

Seat

Remove the 3 fasteners shown in the figure.

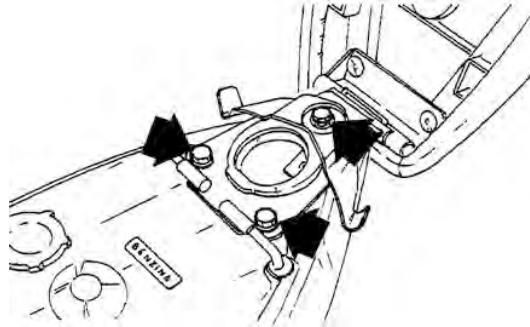

Rear handlebar cover

After removing the rear-view mirrors, the attachments and their seals, remove the four fasteners shown in the figure, detach the electrical wiring and the odo/speedometer cable to replace the dashboard assembly.

Once the handlebar is removed act upon the two lips on the dashboard.

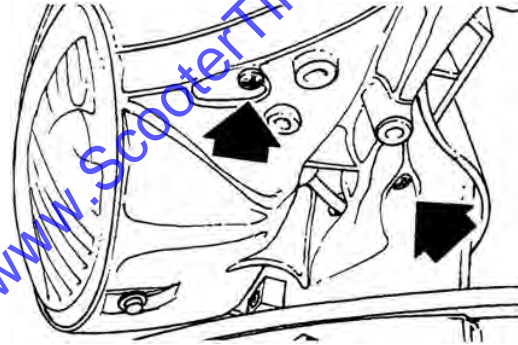

Headlight assy.

After removing the handlebar cover, remove the 2 fasteners show in the figure and the headlight adjusting screw underneath the handlebar.

Detach the wirings. To replace the bulbs simply release the springs holding back the socket and replace any blown bulb.

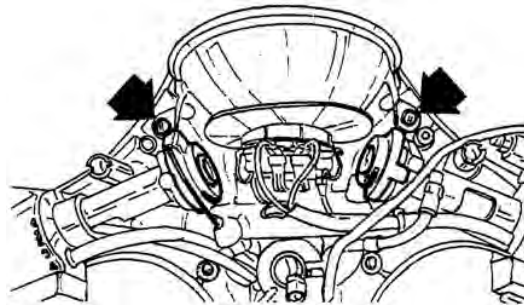

– Remove the 2 fasteners for each turn signal light.

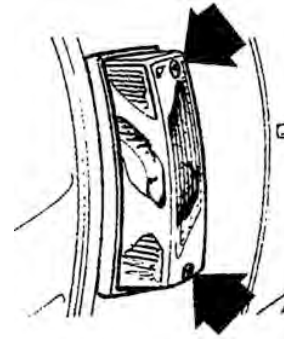

Removing the ignition key-switch when on *off*

To remove the ignition key-switch when in the «ON» position, i.e. steering lock disengage and ignition earthed, proceed as follows:

- Remove the three handlebar fixing screws and the handlebar cover.
- Insert a small screwdriver inside the hole shown in the figure (from underneath the lock body) and push until releasing the securing tongue; hence extract body and master cylinder.

The refitting operations of the lock body and the new master cylinder (on the outer lock body) are as follows:

- Carefully clean the body from any impurity (if the cylinder has been drilled), using compressed air.
- Position the body in its housing after fitting the retaining spring «E».
- Insert the cylinder assembly, with key and tongue «F» facing downwards, halfway inside the lock body, ensuring that during this operation, they is in the «ON» position (the only position that allows the insertion of the cylinder); at the point turn the key leftwards and push as far as the cylinder will go.
- Check the assembly via the key excursion in

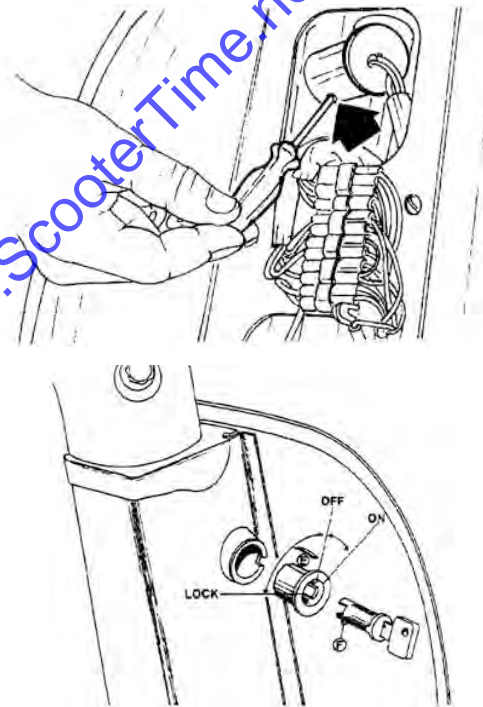

the three positions and proceed by refitting the handlebar cover.

Replace the seat and glove-box cylinders. To replace these follow the operations described for the removal of the cylinder when the ignition key-switch is in the «LOCK» position. If the locks have been left open however, extract the cylinder by pushing lip «F» shown in the figure after having carefully cleaned the housing. Then insert the new cylinder. Bear in mind that for the replacement of the cylinder on the seat lock, it is necessary to remove the lock assembly, acting upon the three screws.

Removing the ignition key-switch when on *lock*

Should it be necessary to replace the steering lock cylinder when the keys have gone missing, proceed as follows:

Cylinder removal: in the event that the key-switch is in the «LOCK» position, it is necessary to **proceed by drilling the cylinder** with the aid of a $\varnothing 8$ mm at least 30 mm long; this allows to release (or destroy) the internal retaining device of the drilled cylinder. Hence extract the body and any residues so to be able to use the body for refitting.

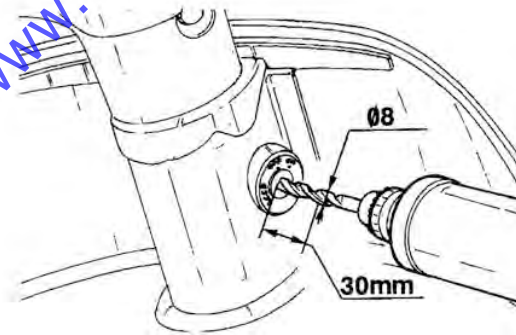

Taillight assy.

- Remove the 2 fixings shown in the figure and replace the blown bulbs.
- Replace, if necessary, the taillight lens.
- To replace the taillight assy., remove the lens, detach the wiring and remove the 2 fasteners

from underneath the frame.

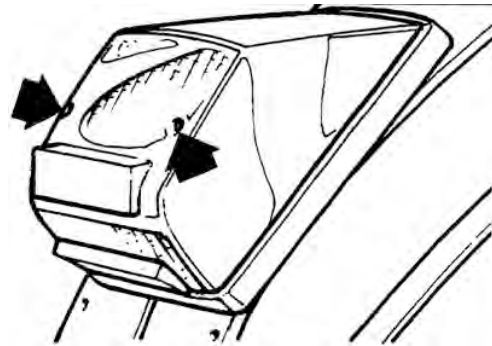

– Remove the 2 fasteners for each turn signal light.

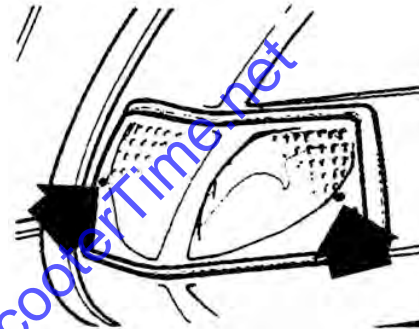

Fuel tank

After removing the seat, detach the electrical connection of the fuel level sensor. Remove the 2 remaining fixings to free the fuel tank assembly. Lift both tanks thus detaching the hoses with the fuel tap shut to separate the fuel-oil tanks. Remove the tank filler cap and insert the special tool through the tube. Proceed by loosening the nut and the acting upon ring «B» until releasing the oil tank

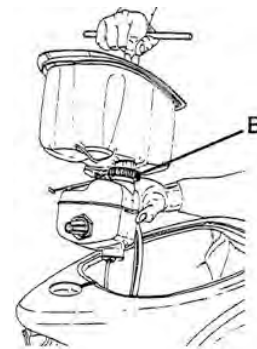

Specific tooling

020321Y Carburetor float removing tool

002850y Oil tank spanner

002973y Fuel tap spanner

Remove the tank filler cap and insert the spanner thus loosening nut «D», hence extract the fuel

tap.

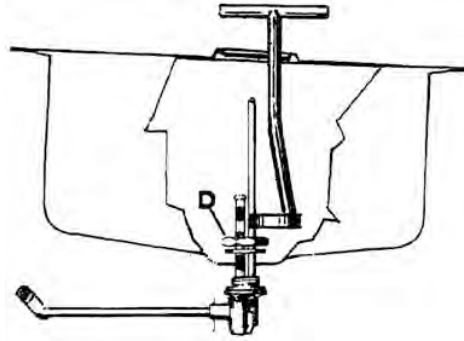

Front mudguard

– Remove the 2 fixings from underneath the mudguard.

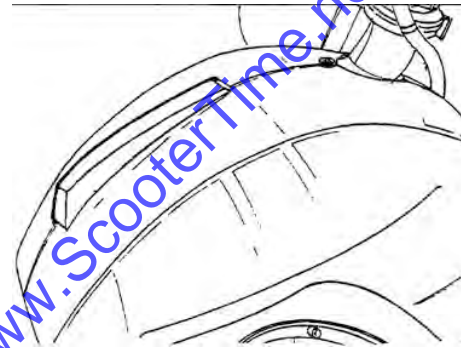

– After removing the handlebar and the steering column assembly, remove the 3 fasteners shown in the figure.

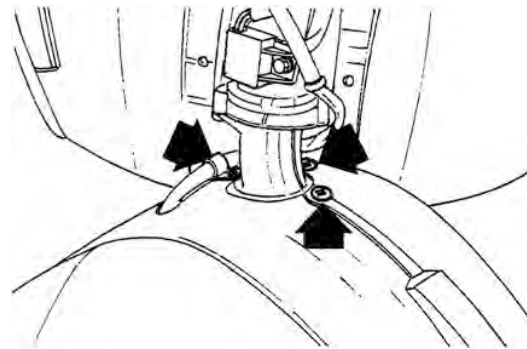

Top-case

Front

- Remove the 2 fixings shown in the figure and the 2 top fasteners from inside the glove-box.
- Remove the glove-box assembly.

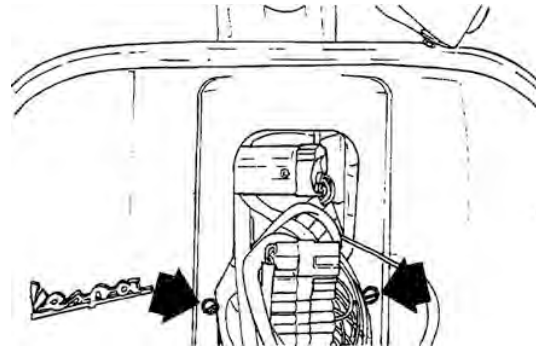

Front central cover

After removing the steering column cover, remove the horn and the grid fixings. Replace the grid.

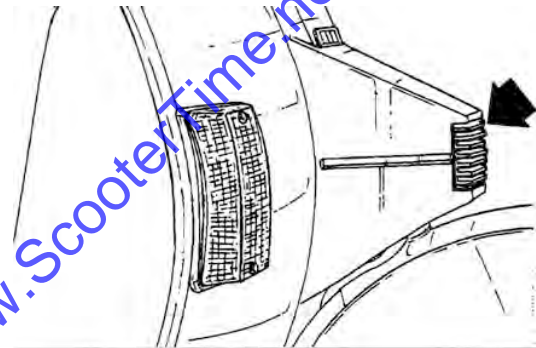

Side Cowlings

Lift the seat and act upon either one of the two lever, according to which cowling must be removed (RHS or LHS)

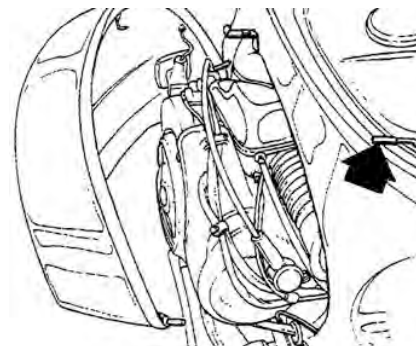

Downloaded from www.ScooterTime.net

INDEX OF TOPICS

PRE-DELIVERY

PRE DE

Downloaded from www.ScooterTime.net

Carry out the listed tests before delivering the vehicle.

WARNING

BE VERY CAREFUL WHEN HANDLING FUEL.

Aesthetic inspection

- Paint
 - Plastic joints
 - Damages
 - Dirt
-

Tightening torques inspection

- All tighten torques summarized in pages 1 - 5.
 - External covers screws.
-

Electrical system

- Fill the battery with acid, and charge with appropriate charger.
 - Ignition key-switch.
 - Low-beam light, high-beam light, warning lights, side-light.
 - Headlight adjustment.
 - Taillight.
 - Stop light (eventually front and rear lights).
 - Turn signal lights and warning lights.
 - Dashboard illumination.
 - Horn.
 - Starter button.
-

CAUTION

TO ENSURE MAXIMUM PERFORMANCE, THE BATTERY MUST BE CHARGED BEFORE USE. INADEQUATE CHARGING OF THE BATTERY BEFORE IT IS FIRST USED WITH A LOW LEVEL OF THE ELECTROLYTE SHORTENS THE LIFE OF THE BATTERY.

WARNING

BEFORE RECHARGING THE BATTERY, REMOVE THE PLUGS OF EACH ELEMENT. KEEP SPARKS AND FREE FLAMES AWAY FROM THE BATTERY WHILE RECHARGING. REMOVE THE BATTERY FROM THE VEHICLE DISCONNECTING THE NEGATIVE TERMINAL FIRST.

CAUTION

WHEN INSTALLING THE BATTERY, FIRST FIX THE POSITIVE CABLE AND THEN THE NEGATIVE

CABLE.**CAUTION**

THE BATTERY ELECTROLYTE IS DANGEROUS AND MAY CAUSE SERIOUS BURNS. IT CONTAINS SULPHURIC ACID. CONTACT WITH EYES, SKIN AND CLOTHES SHOULD BE AVOIDED.

IN THE EVENT OF CONTACT WITH EYES AND SKIN, RINSE THOROUGHLY WITH WATER FOR ABOUT 15 MINUTES AND CONSULT A DOCTOR IMMEDIATELY.

IN THE EVENT OF FLUID INGESTION, DRINK ABUNDANT WATER OR MILK IMMEDIATELY.

THEN, DRINK MILK OF MAGNESIA, BEATEN EGG OR VEGETABLE OIL. CONSULT A DOCTOR IMMEDIATELY.

BATTERIES PRODUCE EXPLOSIVE GASES; KEEP AWAY FROM FREE FLAMES, SPARKS OR CIGARETTES; IF RECHARGING THE BATTERY IN A CLOSED ENVIRONMENT, ENSURE PROPER VENTILATION.

ALWAYS SHIELD YOUR EYES WHEN WORKING CLOSE TO BATTERIES.

KEEP AWAY FROM THE REACH OF CHILDREN.

CAUTION

NEVER USE FUSES HAVING A CAPACITY GREATER THAN THE RECOMMENDED VALUE. THE USE OF A FUSE OF UNSUITABLE CAPACITY MAY RESULT IN SERIOUS DAMAGES TO THE WHOLE VEHICLE OR EVEN CULMINATE IN A FIRE.

Levels check

- Brake fluid.
 - Gear-box.
 - Oil tank.
-

Road test

- Cold start.
 - Speedometer check.
 - Throttle check.
 - Riding stability.
 - Front and rear brake efficiency.
 - Front and rear shock-absorbers.
 - Anomalous noises.
 - Hot engine restart.
 - Leakages (after road-test).
-

Functional inspection**Other**

- Tire pressure.
-

- All locks.
- Rear-view mirrors and accessory fitting.
- Tooling kit, owner manual, warranty certificate and customer service card.

CAUTION

CHECK THE INFLATING PRESSURES WHEN THE TIRES ARE AT AMBIENT TEMPERATURE.

CAUTION

NOT EXCEED THE RECOMMENDED INFLATING PRESSURES AS THE TIRES MAY BURST.

- Brake lever excursion.
 - Throttle excursion and adjustment.
 - Homogeneous steering turning.
-

Downloaded from www.ScooterTime.net

INDEX OF TOPICS

TIME

TIME

Downloaded from www.ScooterTime.net

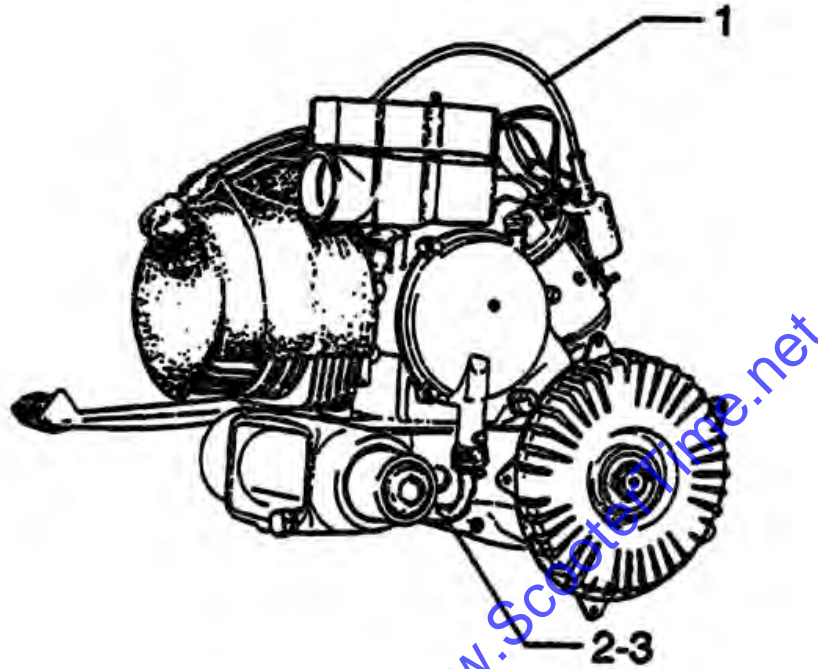
Engine
**ENGINE**

	Code	Action	Duration
1	001001	Engine from the frame - removal and refitting	
2	003064	Engine oil - replacement	
3	003057	Engine attachment - Nuts tightening	

Crankshaft

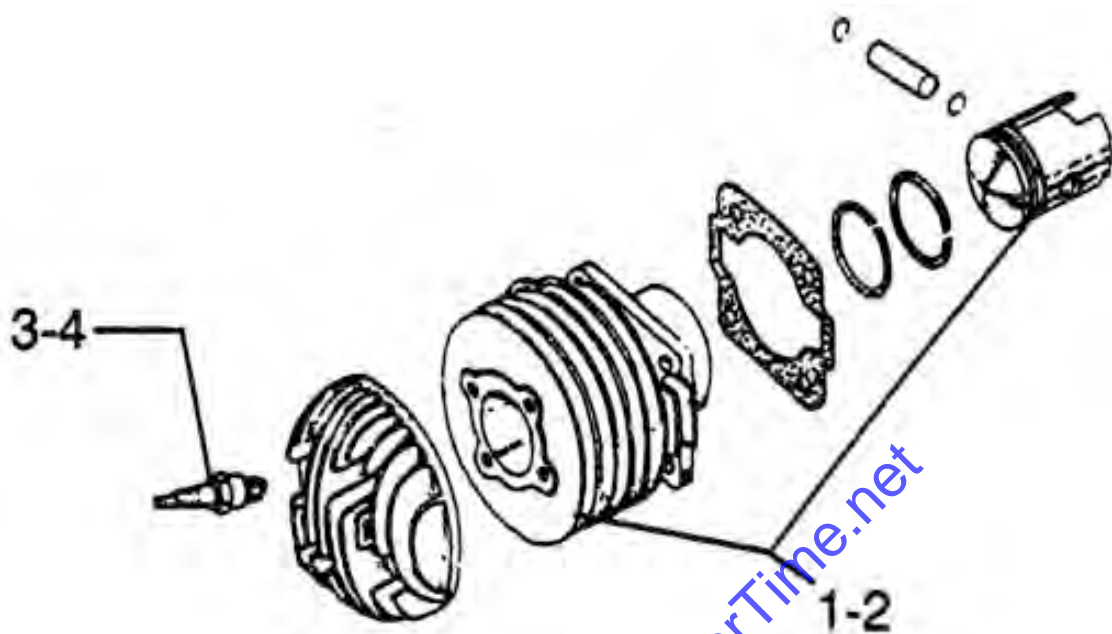

WRIST PIN PISTON CYLINDER ASSY

	Code	Action	Duration
1	001002	Cylinder/piston - Replacement	
2	001107	Cylinder/Piston - Overhaul/ Cleaning	
3	001093	Spark plug - Replacement	
4	001094	Spark plug cap - Replacement	

Downloaded from www.ScooterTime.net

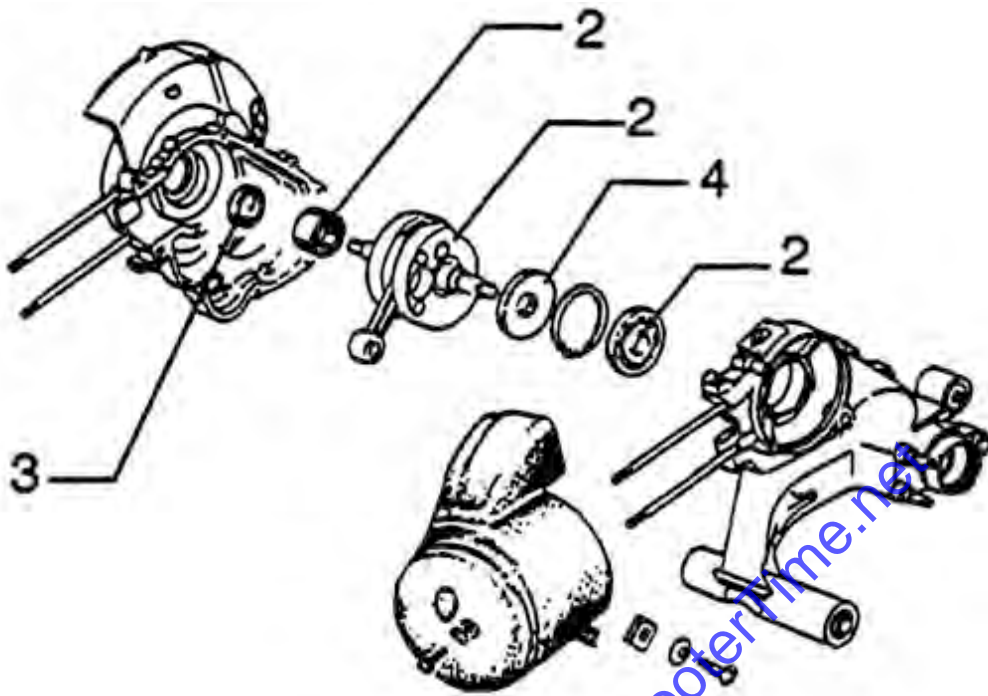

ENGINE SHROUD - CRANKCASE BEARINGS

	Code	Action	Duration
1	001117	Engine driving shaft - Replacement	
2	001118	Crankcase bearings - Replacement	
3	001099	Oil seal, flywheel side - Replacement	
4	001100	Clutch-side oil seal - Replacement	

Flywheel cover

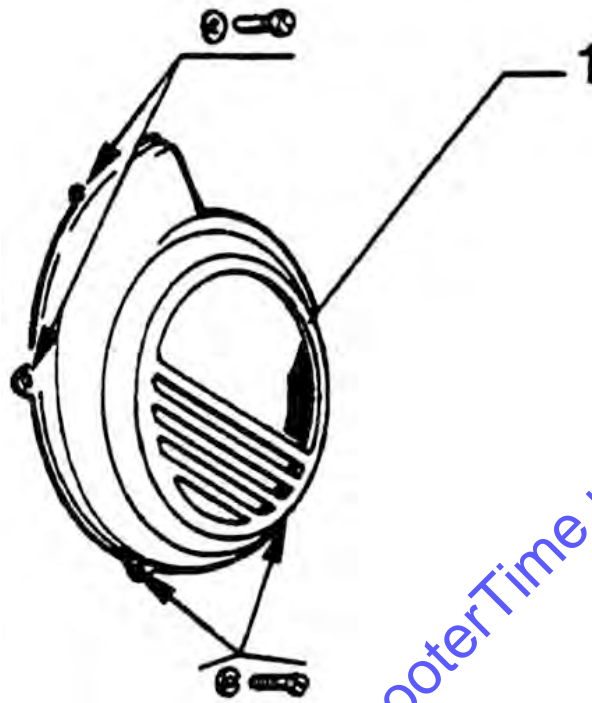

FAN COVER

	Code	Action	Duration
1	001087	Flywheel housing - Replacement	

Oil pump

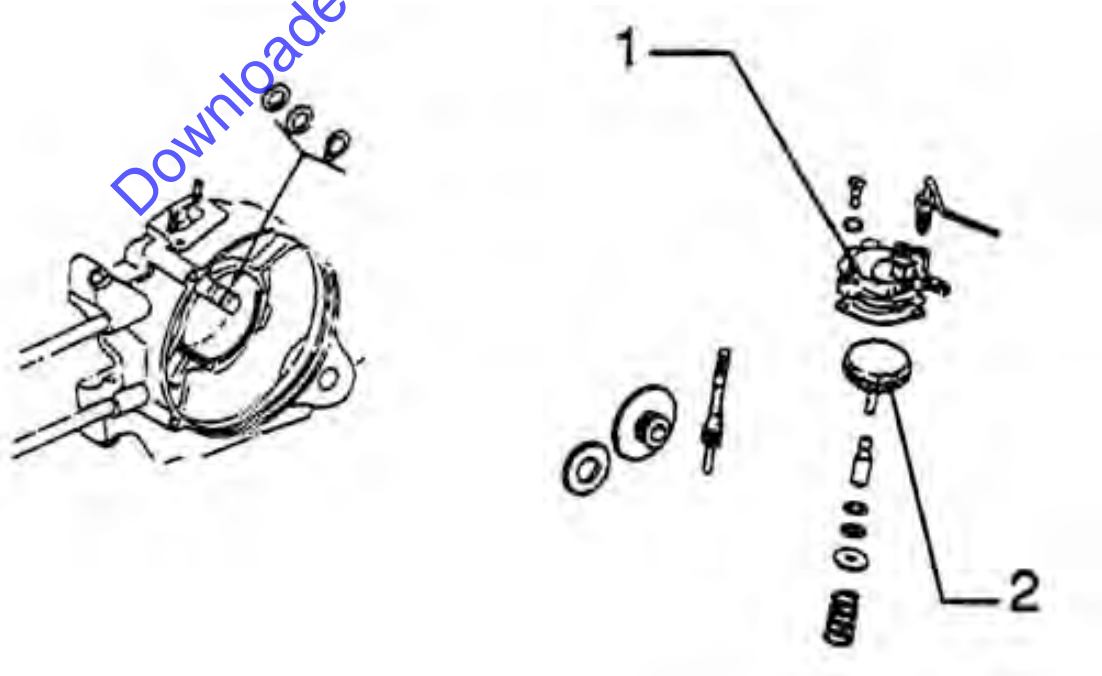

AUTOMATIC MIXER

	Code	Action	Duration
1	001018	Mixer - Replacement	
2	001028	Oil pump drive shaft - Replacement	

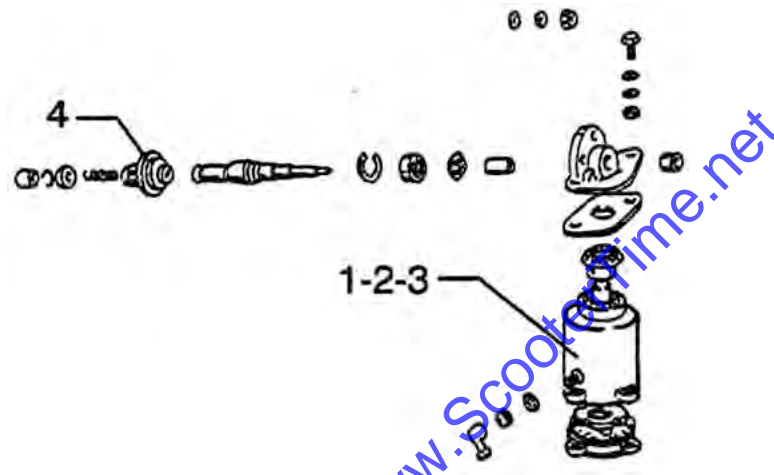
Starter motor**STARTER MOTOR**

	Code	Action	Duration
1	001020	Starting motor - Replacement	
2	001039	Starter motor brushes - Replacement	
3	001038	Starter motor - Overhaul	
4	001017	Starter motor shaft - Replacement	

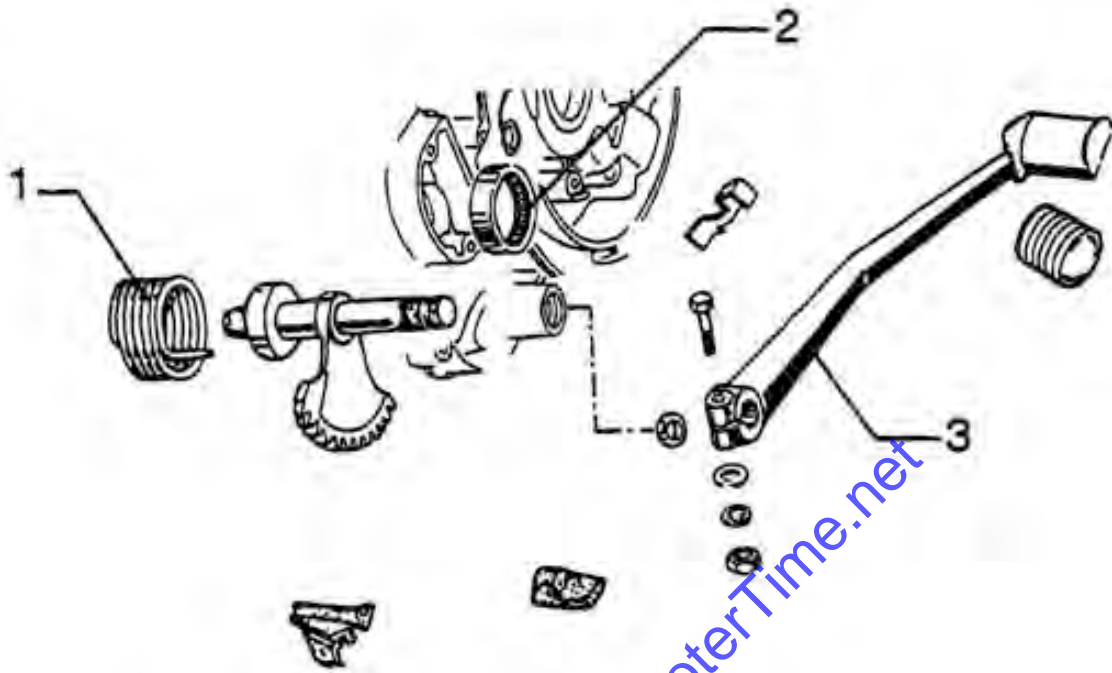

KICK-START LEVER

	Code	Action	Duration
1	008008	Kick-starter gear spring - Replacement	
2	001120	Crankcase bearings - Replacements	
3	001084	Starting lever - Replacement	

Flywheel magneto

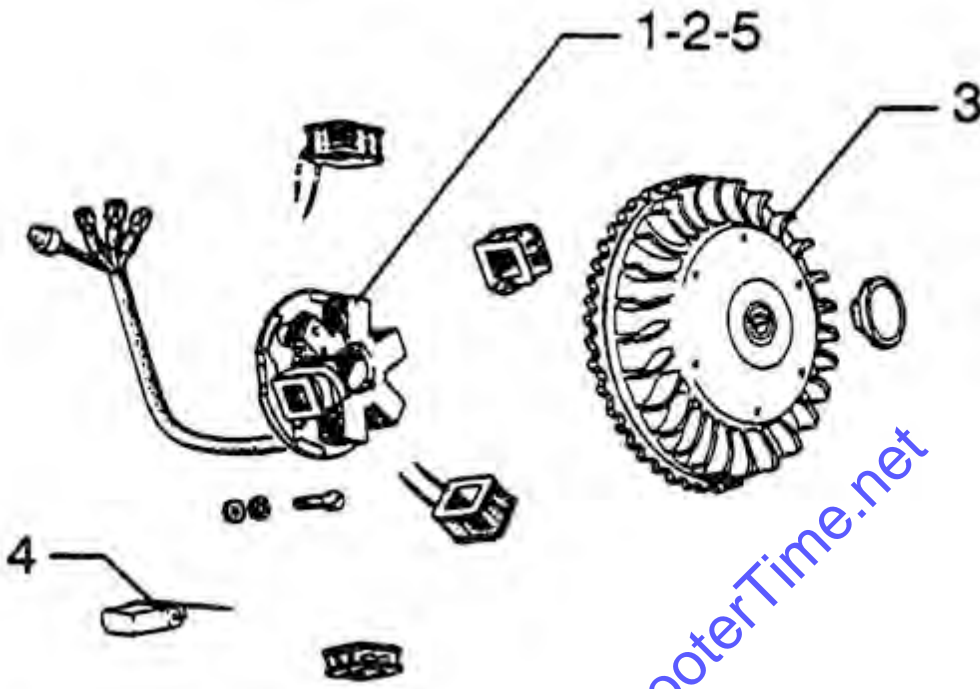

FLYWHEEL MAGNETO

	Code	Action	Duration
1	001067	Stator - Removal and refitting	
2	001004	Stator - Overhaul	
3	001058	Flywheel - Replacement	
4	001059	Pick-up - Replacement	
5	003052	Ignition timing	

Carburettor

Downloaded from www.scootertime.net

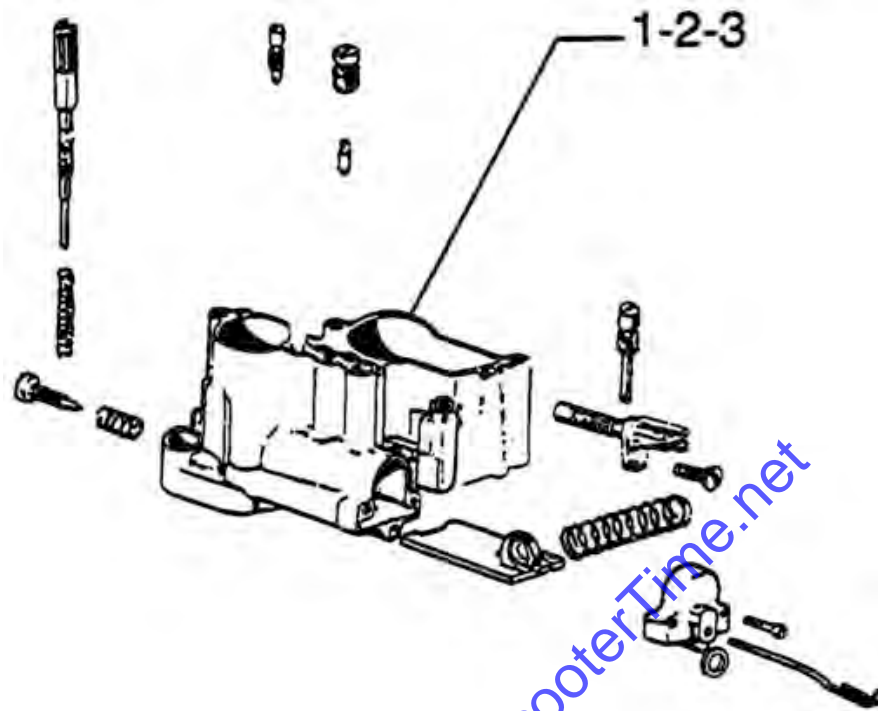

CARBURETTOR

	Code	Action	Duration
1	001063	Carburettor - Replacement	
2	001008	Carburatore - Revisione	
3	003058	Carburettor - Adjustment	

Exhaust pipe

Downloaded from www.ScooterTime.net

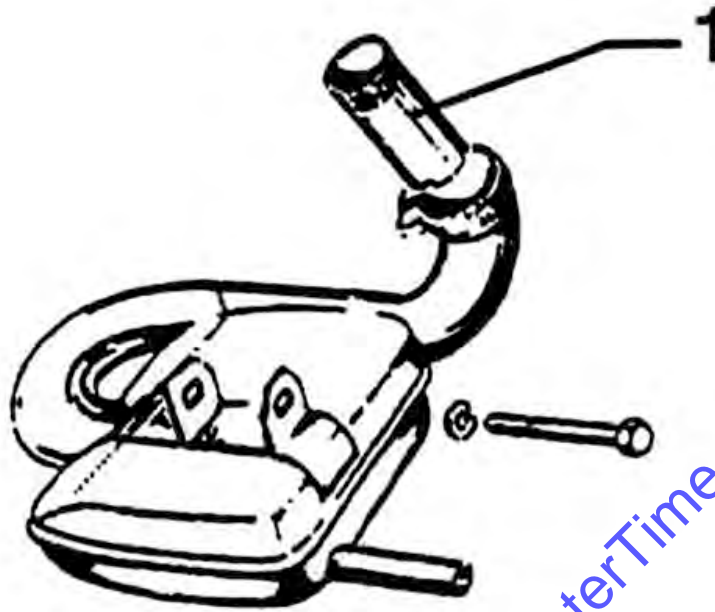

EXHAUST PIPE

	Code	Action	Duration
1	001009	Exhaust pipe - Replacement	

Air cleaner

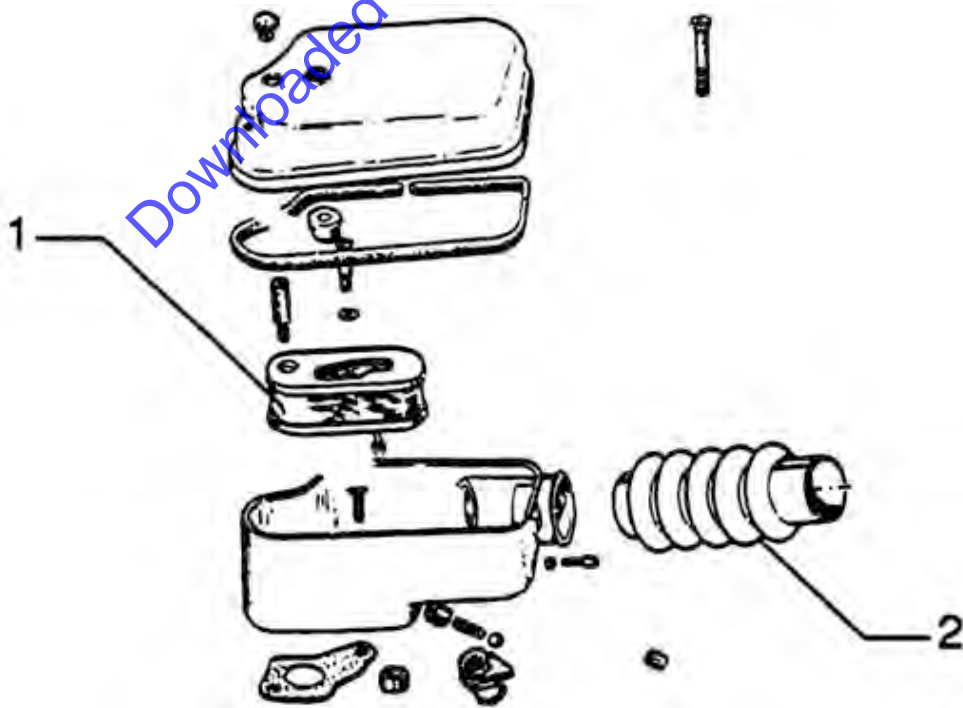

AIR CLEANER

	Code	Action	Duration
1	001014	Air filter - Replacement	
2	001027	Air-cleaner/frame bellow - Replacement	

Frame

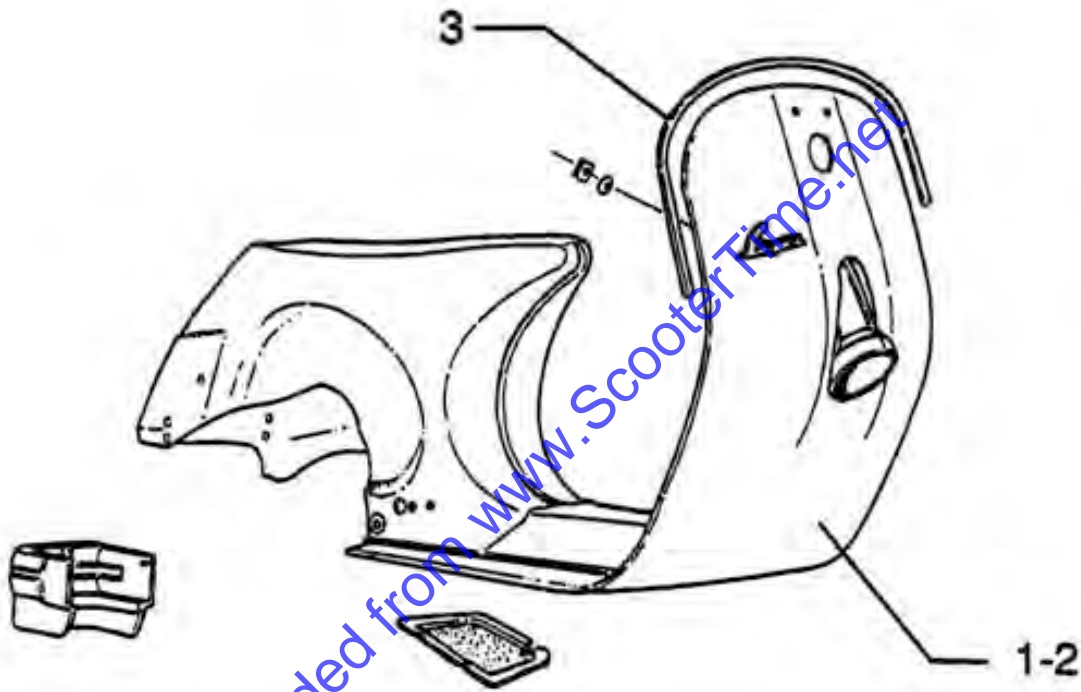

FRAME

	Code	Action	Duration
1	004001	Frame - Replacement	
2	006001	Frame - Painting	
3	004023	Front shield beading - Replacement	

Centre-stand



CENTRE-STAND

	Code	Action	Duration
1	004004	Centre-stand - Replacement	

Legshield spoiler

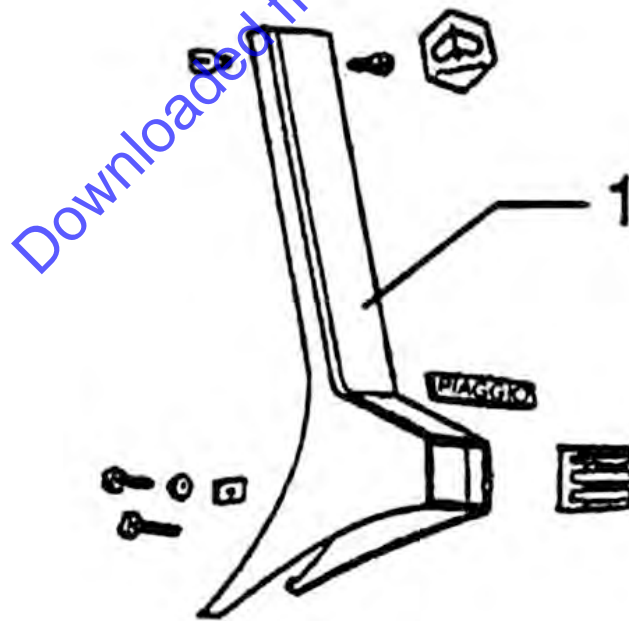

STEERING COLUMN FAIRING

	Code	Action	Duration
1	004024	Steering column fairing - Replacement	

Side fairings

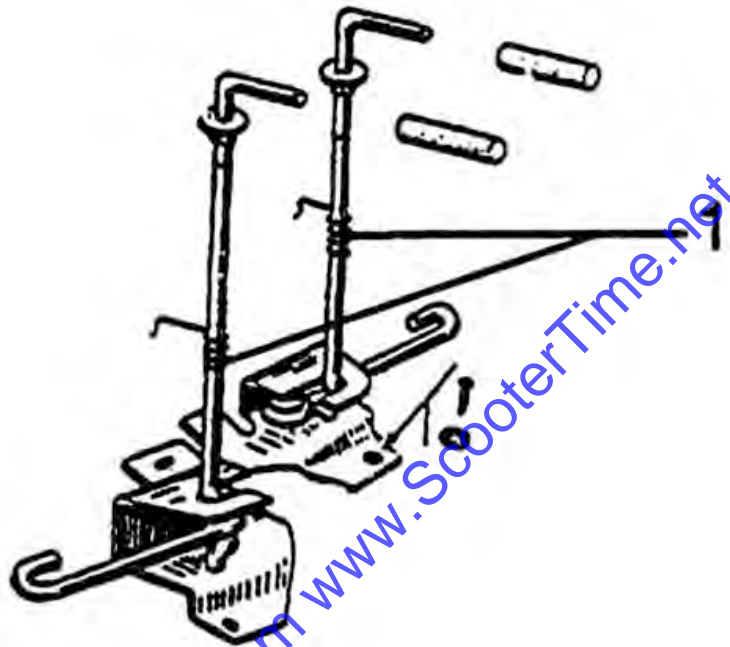

SIDE FAIRING LOCKS

	Code	Action	Duration
1	004025	Side fairing locks - Replacement	

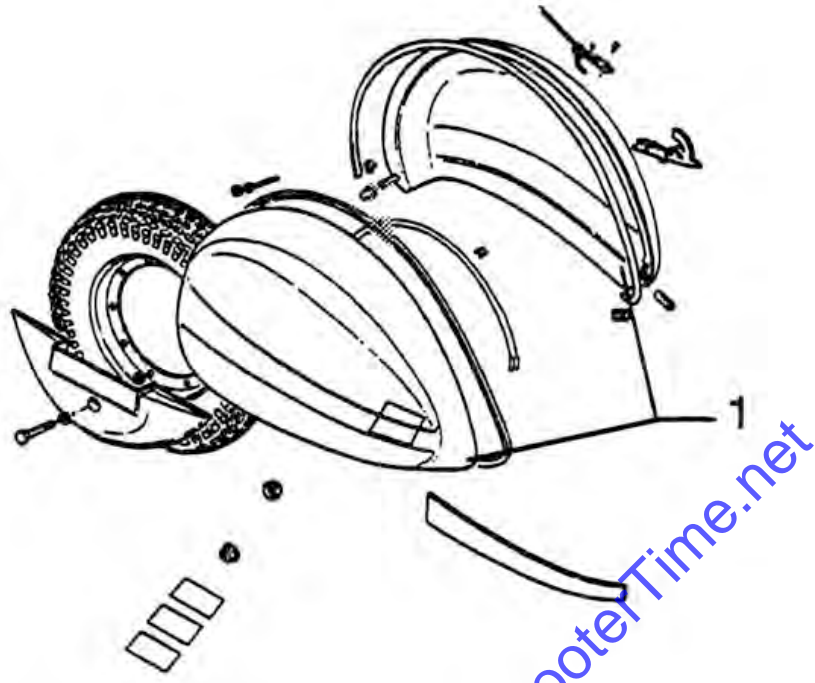

WHEEL SIDE FAIRINGS

Code	Action	Duration
1	Side fairings - Painting	

Footrests

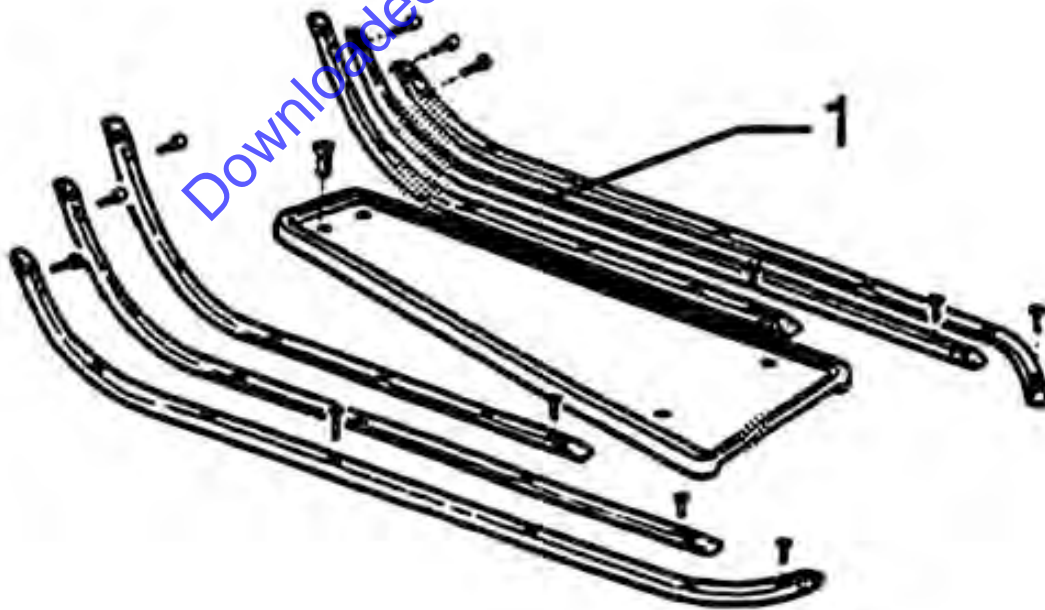

FOOTRESTS

	Code	Action	Duration
1	004015	Footrests - Replacement	

Rear cover

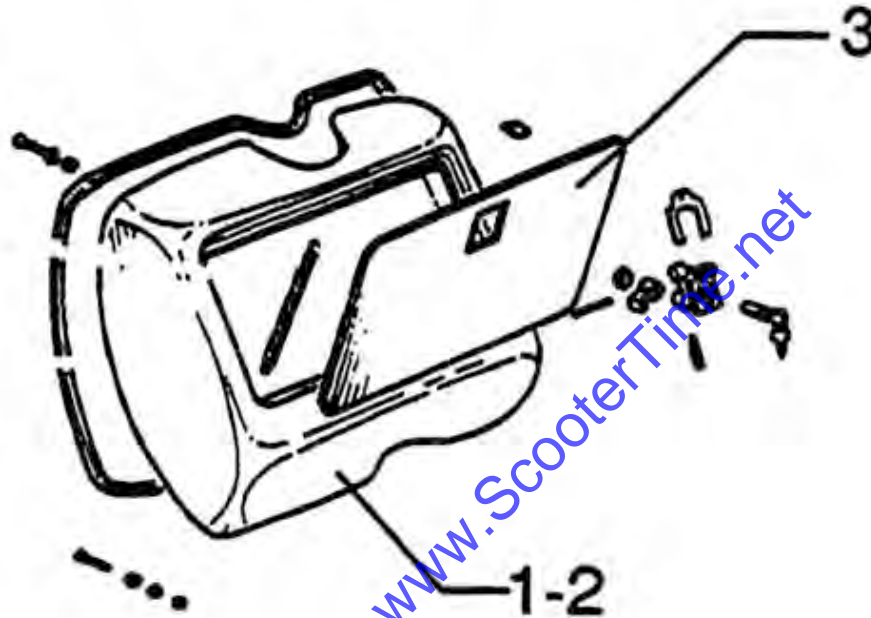

GLOVE-BOX

	Code	Action	Duration
1	004083	Glove-box - Replacement	
2	006019	Glove-box - Painting	
3	004081	Glove-box door - Replacement	

Mudguard

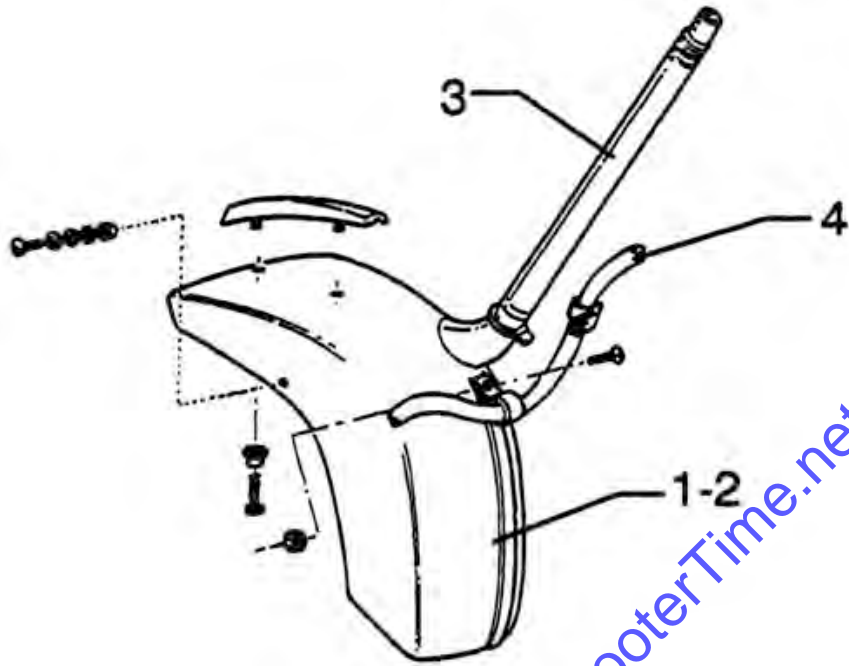
**FRONT MUDGUARD**

	Code	Action	Duration
1	004002	Front mudguard - Replacement	
2	006003	Front mudguard - Painting	
3	003045	Steering column - Replacement	

Fuel tank

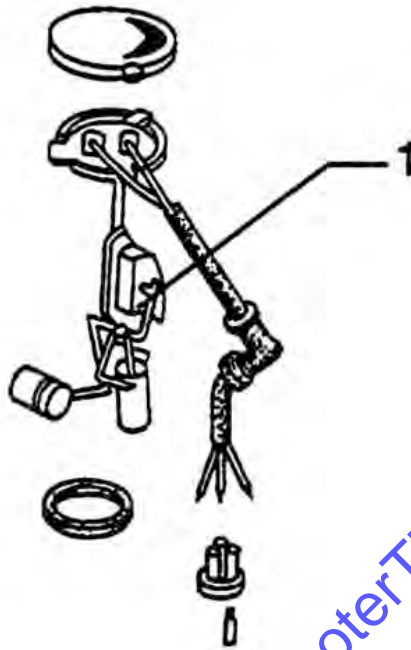

FUEL LEVEL SENSOR

	Code	Action	Duration
1	005010	Fuel tank float - Replacement	

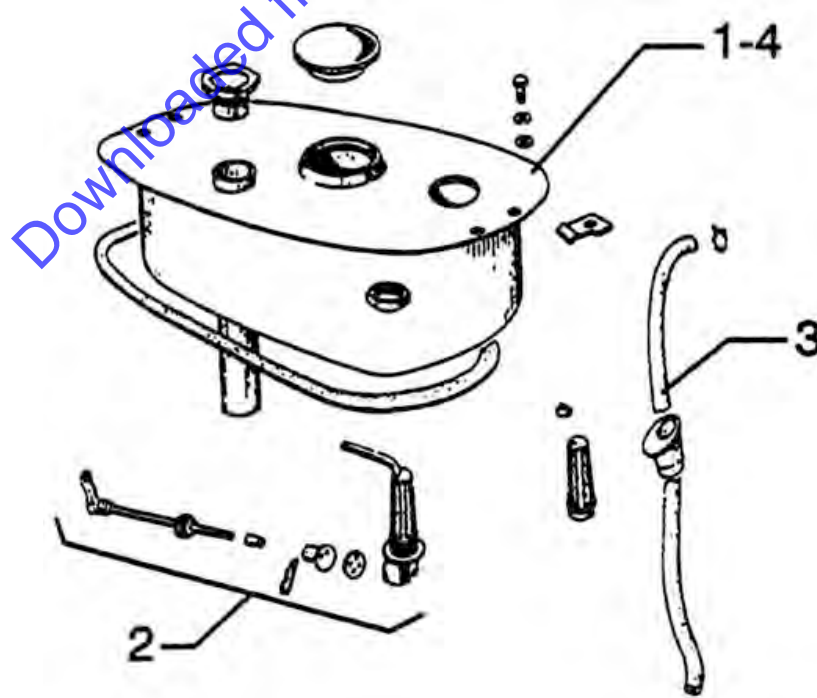

FUEL TANK

	Code	Action	Duration
1	004005	Fuel tank - Replacement	
2	004007	Fuel tap - Replacement	
3	004110	Fuel tank hose - Replacement	
4	006024	Fuel tank - Painting	

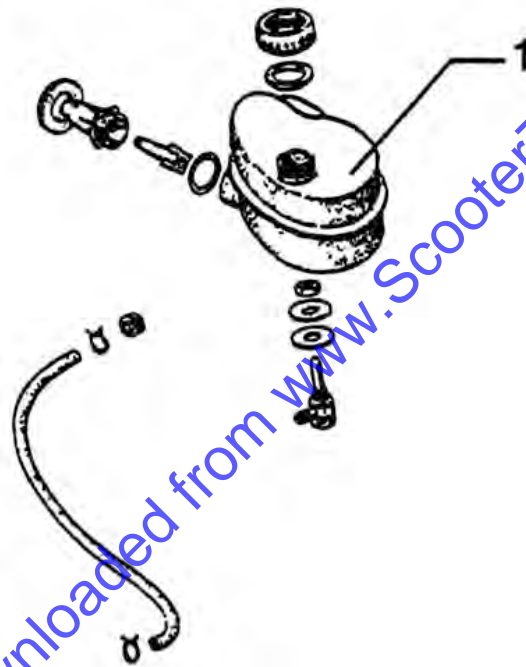
Tank oil**OIL TANK**

	Code	Action	Duration
1	004017	Oil tank - Replacement	

Rear shock-absorber

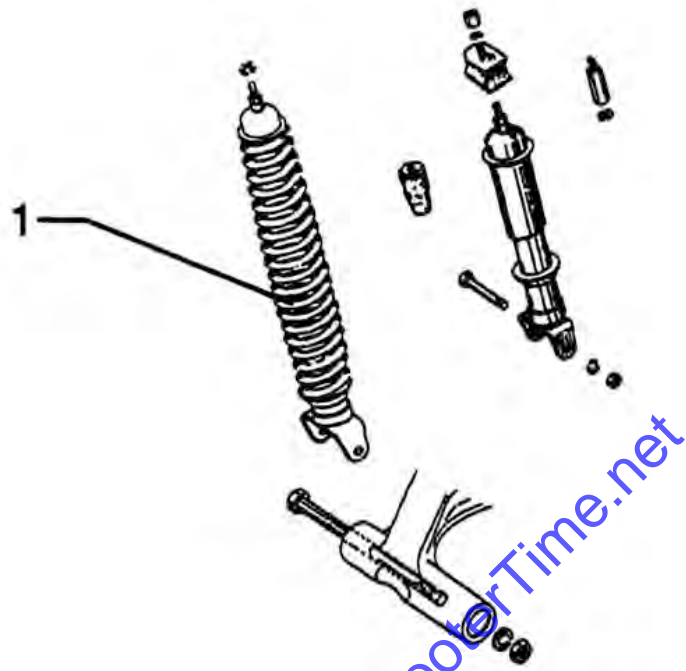

REAR SHOCK-ABSORBER

	Code	Action	Duration
1	003007	Rear shock-absorber - Removal and refitting	

Steering column bearings

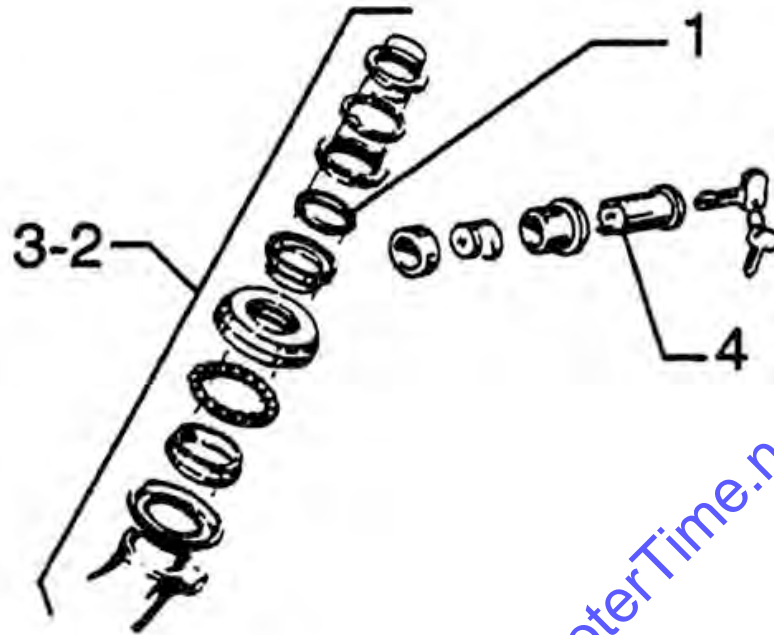

STEERING COLUMN BEARINGS

	Code	Action	Duration
1	003002	Steering bearings - Replacement	
2	004119	Steering support bearing - Replacement	
3	003073	Steering play - Adjustment	
4	004010	Steering lock - Replacement	

Handlebar components

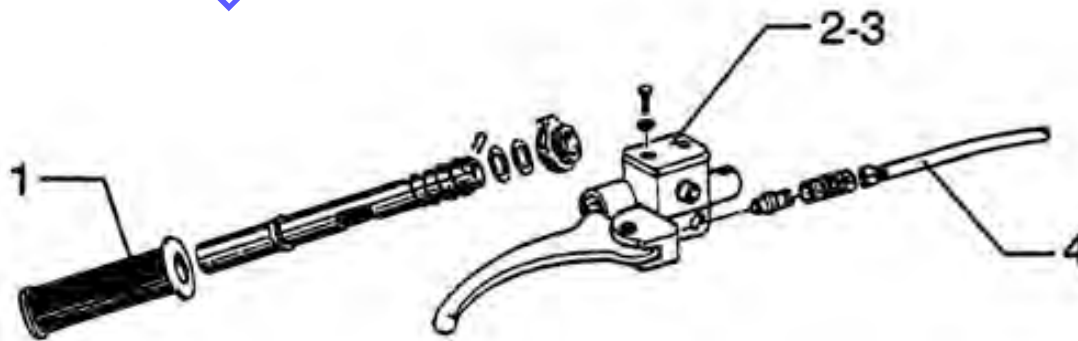

HANDLEBAR COMPONENTS AND BRAKE FLUID PUMP

	Code	Action	Duration
1	002059	RHS twist-grip - Replacement	
2	002024	Front brake pump - Removal and refitting	
3	002047	Front brake fluid - Replacement and circuit bleeding	
4	002021	Front brake hose - Removal and refitting	

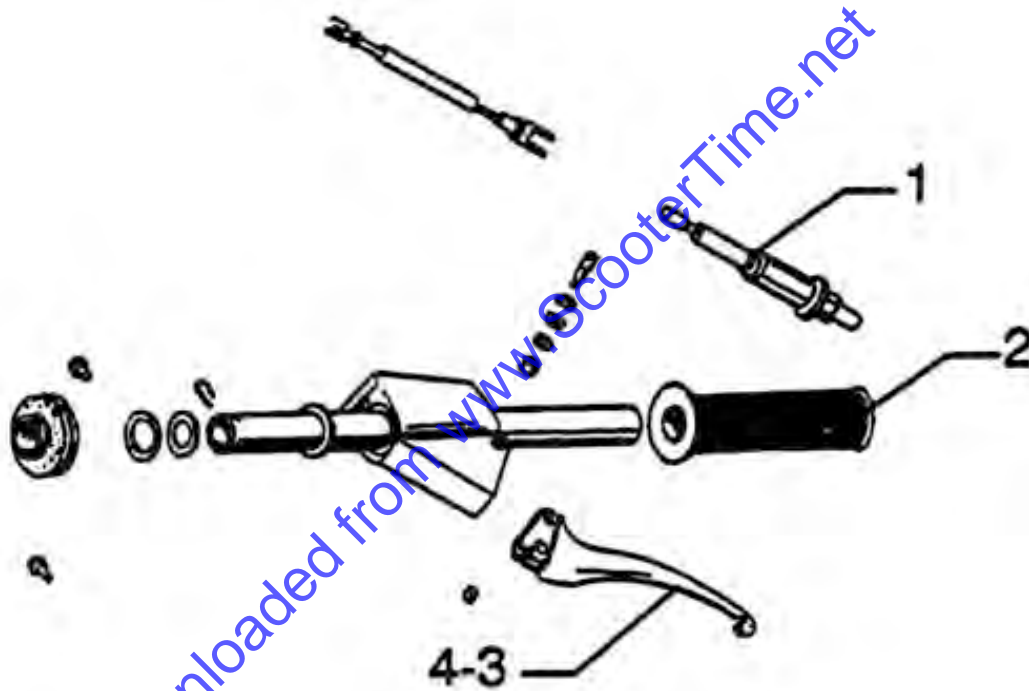

GEAR-SHIFTER TWIST-GRIP

	Code	Action	Duration
1	005062	Neutral switch - Replacement	
2	002071	Left knob - Replacement	
3	002037	Complete gas control - Replacement	
4	001035	Clutch lever - Replacement	

Seat

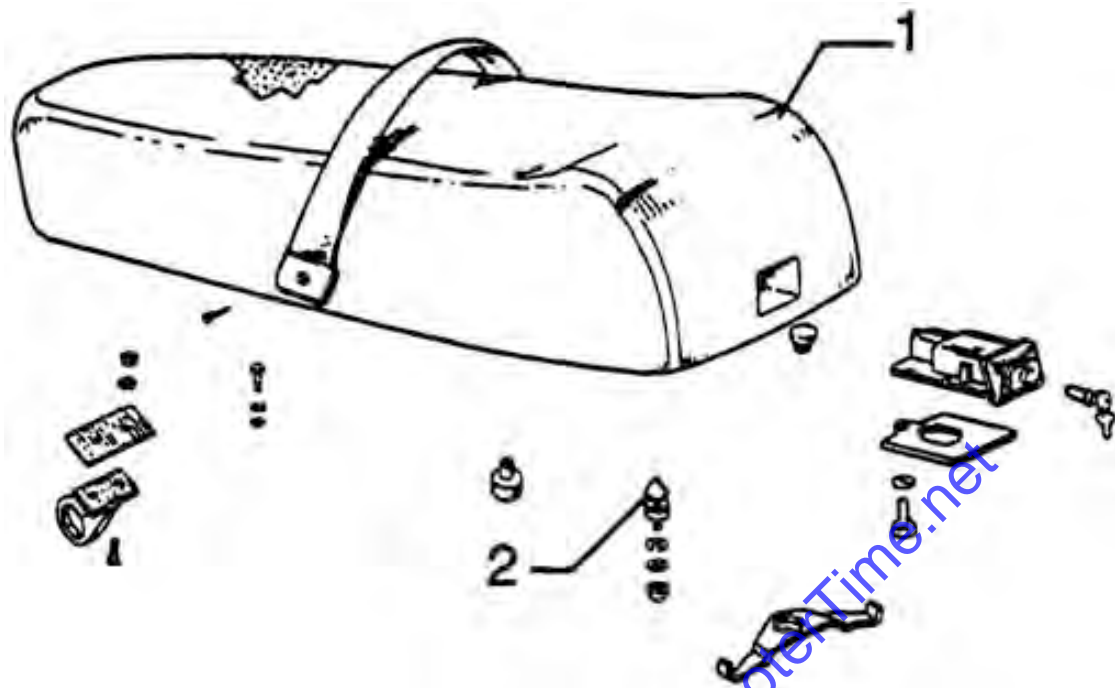

SEAT

	Code	Action	Duration
1	004003	Saddle - Replacement	
2	004054	Seat lock - Replacement	

Instrument panel

Downloaded from www.ScooterTime.net

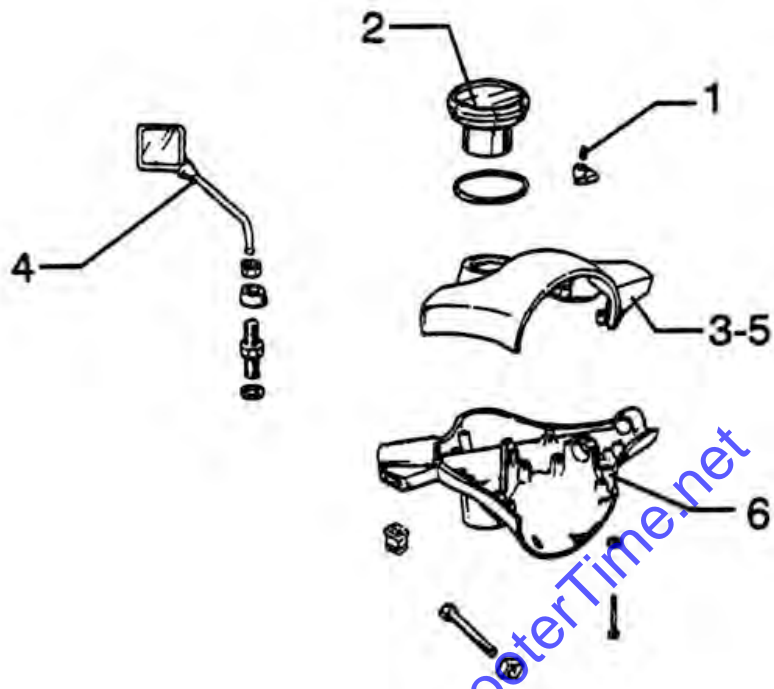

HANDLEBAR COVERS AND DASHBOARD

	Code	Action	Duration
1	005038	Dashboard warning lights - Replacement	
2	005014	Odometer - Replacement	
3	006010	Top handlebar cover - Painting	
4	004066	Rear-view mirror - Replacement	
5	003001	Top handlebar cover - Removal and Refitting	
6	006011	Lower handlebar cover - Painting	

Turn signal lights

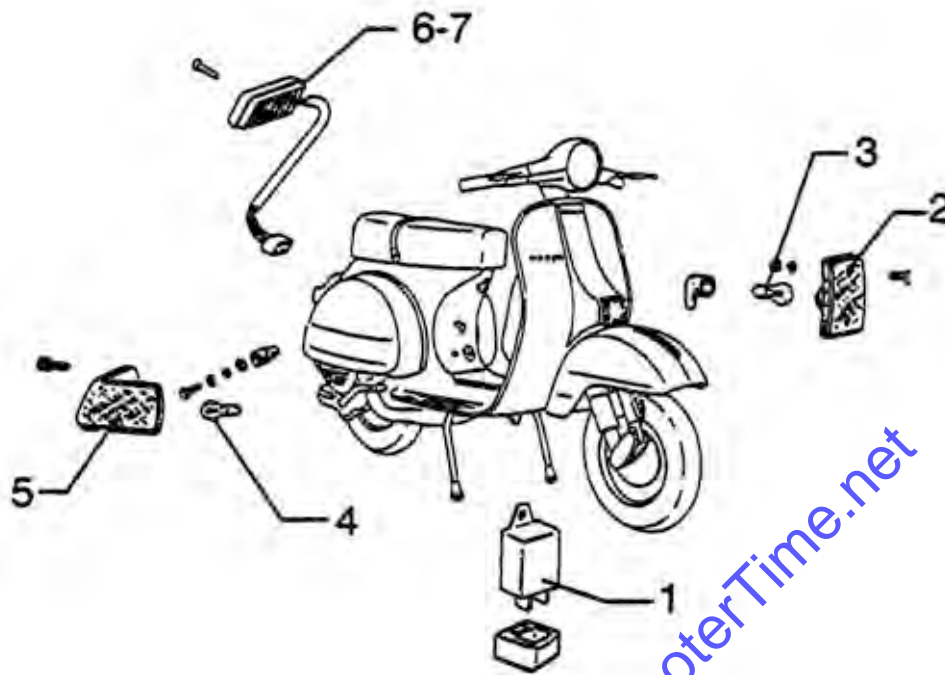

TURN SIGNAL LIGHTS

	Code	Action	Duration
1	005011	Starter relay - Replacement	
2	005012	Front turn signal light - Replacement	
3	005067	Front direction indicator bulb - Replacement	
4	005068	Rear direction indicator lamp - Replacement	
5	005022	Rear turn signal light- Replacement	
6	005006	Turn signals switch - Replacement	
7	005039	Headlight switch - Replacement	

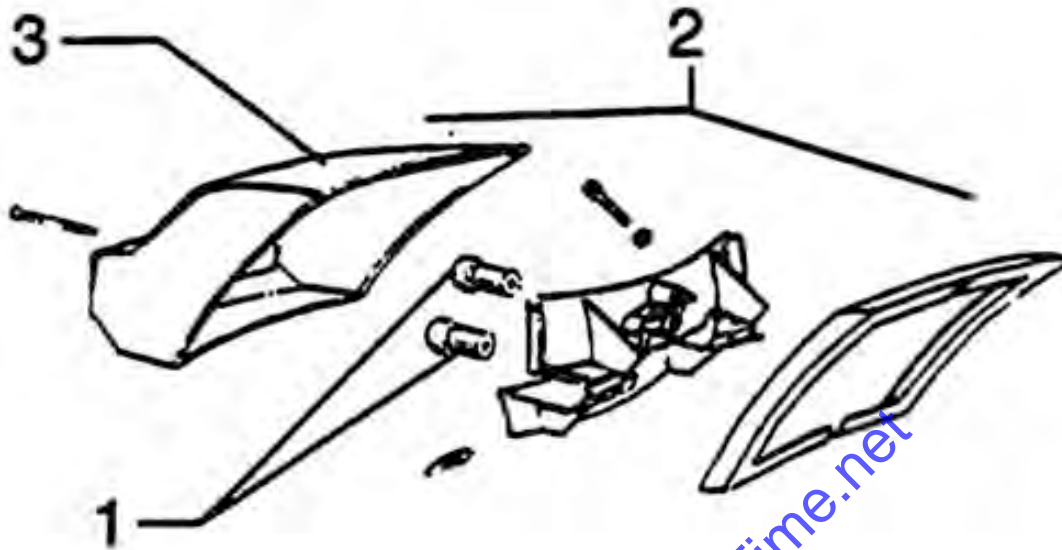

TAILLIGHT

	Code	Action	Duration
1	005066	Rear light bulbs - Replacement	
2	005005	Taillight - Replacement	
3	005028	Rear optical unit glass - Replacement	

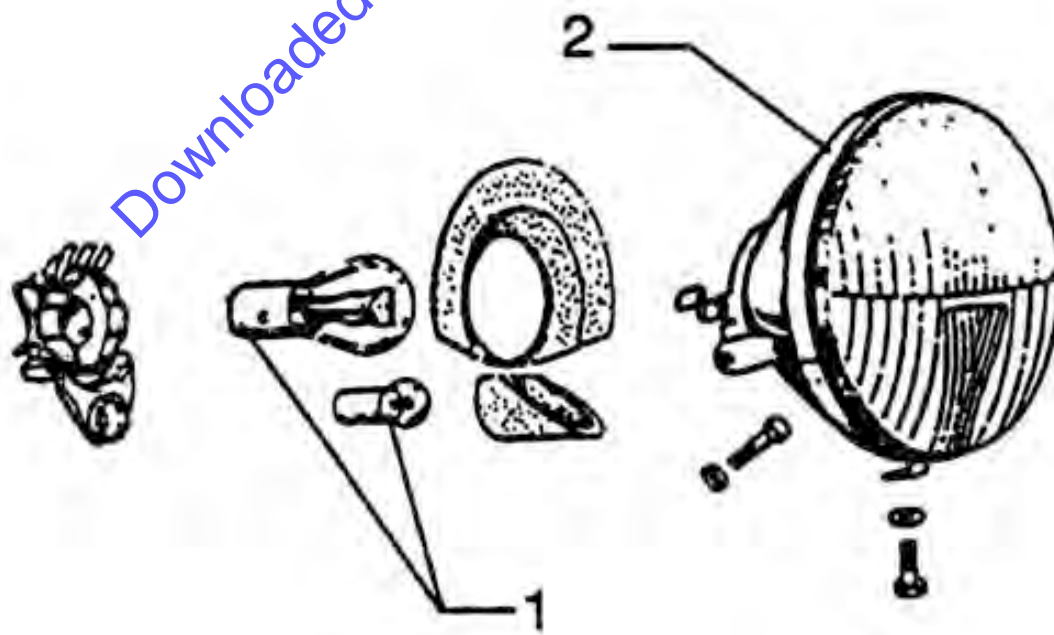

HEADLIGHT

	Code	Action	Duration
1	005008	Headlight bulbs - Replacement	
2	005002	Front number plate lamp - Replacement	

Front wheel

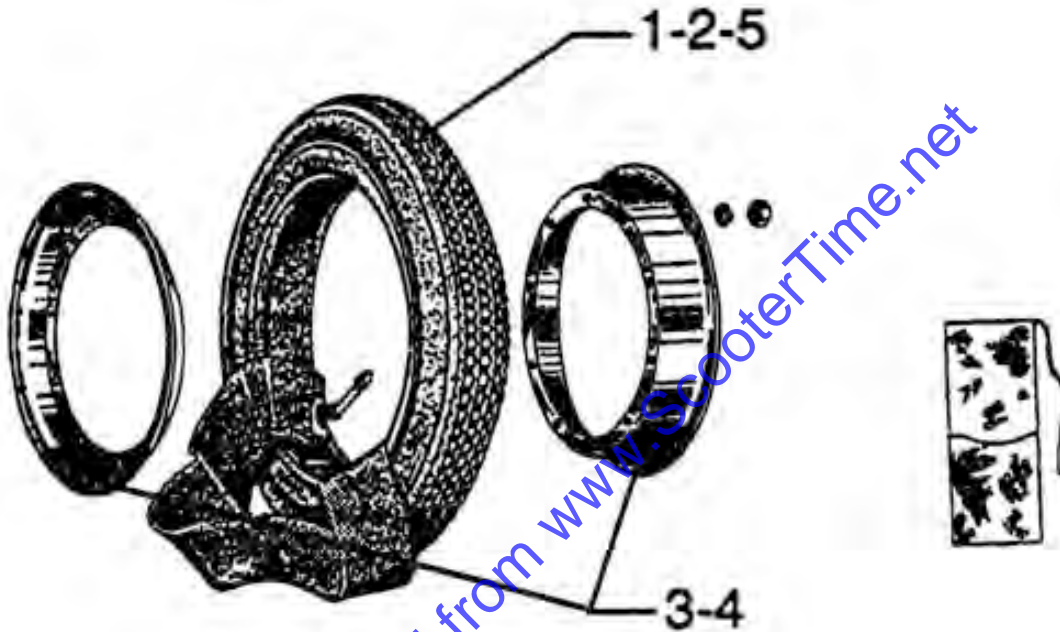

WHEEL

	Code	Action	Duration
1	004123	Front wheel - Replacement	
2	003047	Front tyre - Replacement	
3	003037	Front wheel rim - Removal and refitting	
4	006018	Wheel rim - Painting	
5	003063	Tyre pressure - Check	

Electric devices

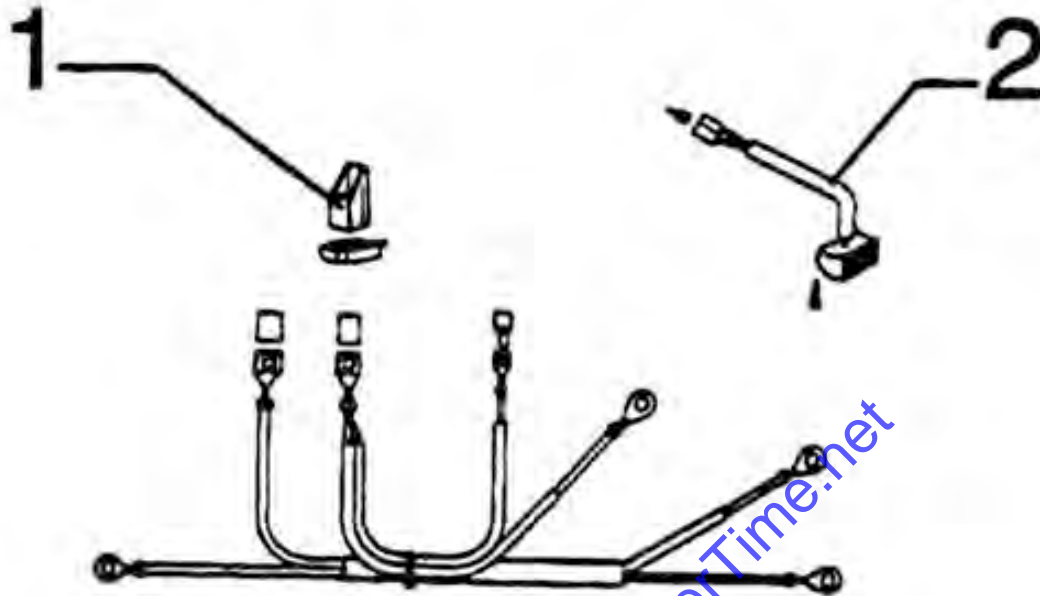

ELECTRICAL DEVICES

	Code	Action	Duration
1	005013	Electronic blinker - Replacement	
2	005045	Starter motor wire harness - Replacement	

Downloaded from www.ScooterTime.net

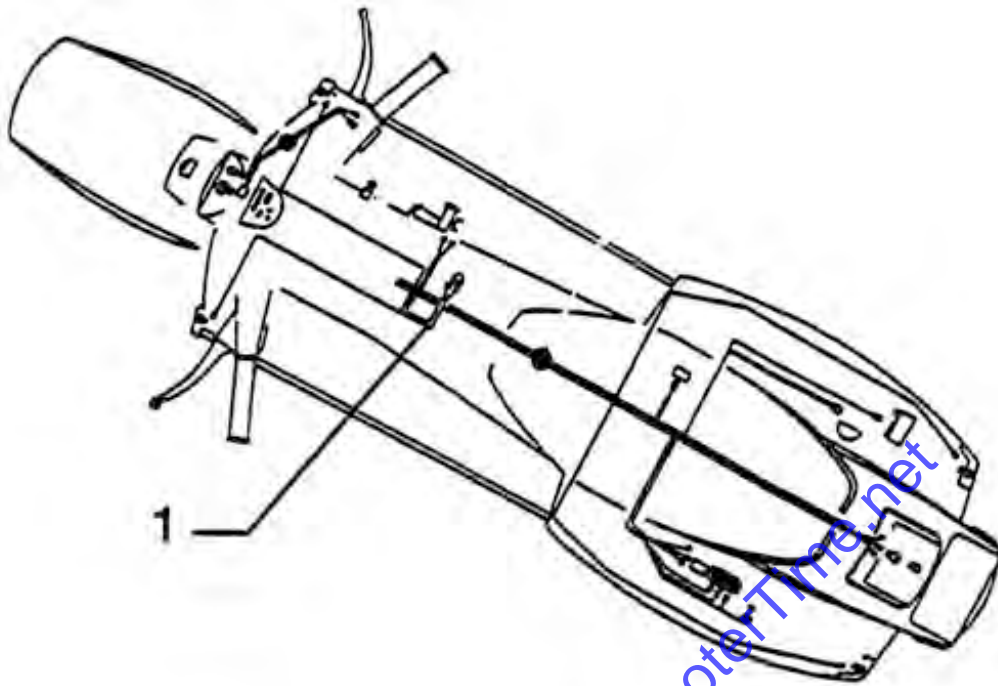

ELECTRICAL CONNECTIONS

1	Code	Action	Duration
1	005001	Electric circuit - Replacement and Refitting	

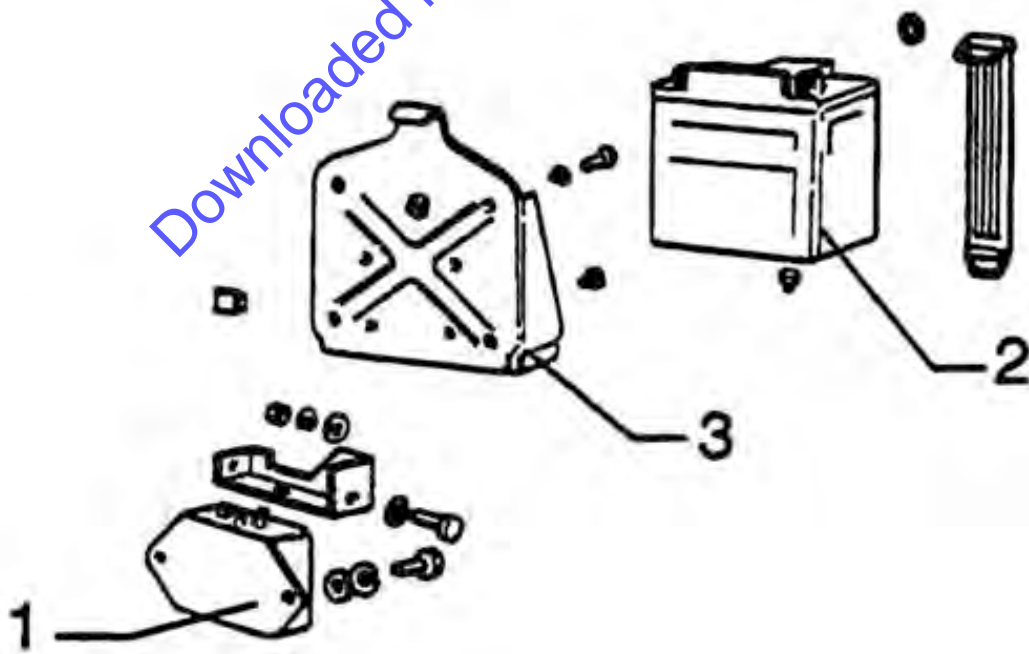

BATTERY - VOLTAGE REGULATOR

	Code	Action	Duration
1	005009	Voltage regulator - Replacement	
2	005007	Battery - Replacement	
3	004071	Battery housing - Replacement	

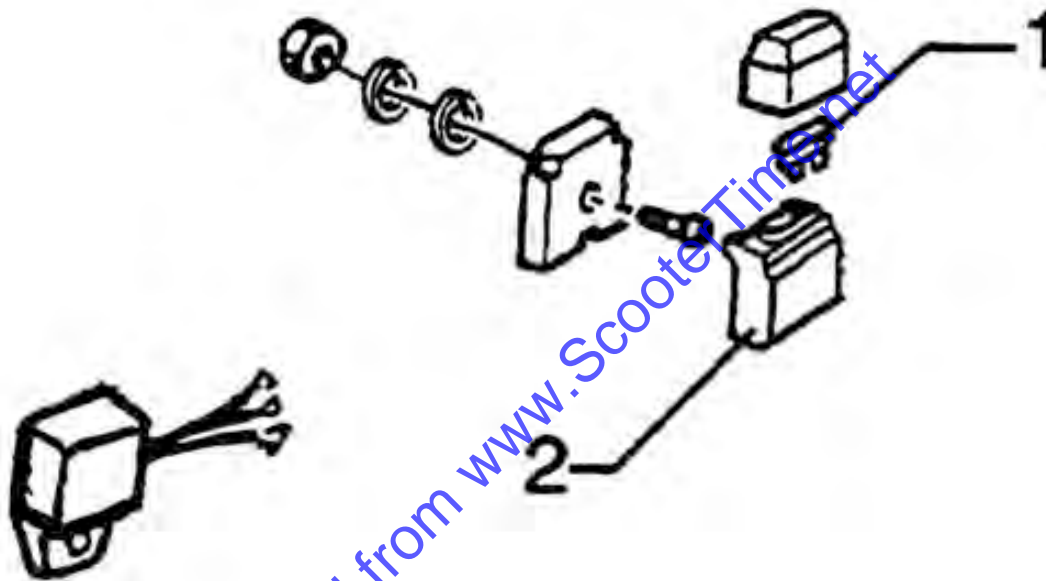

ELECTRICAL DEVICES

	Code	Action	Duration
1	005024	Battery fuse - Replacement	
2	005025	Battery fuse holder - Replacement	

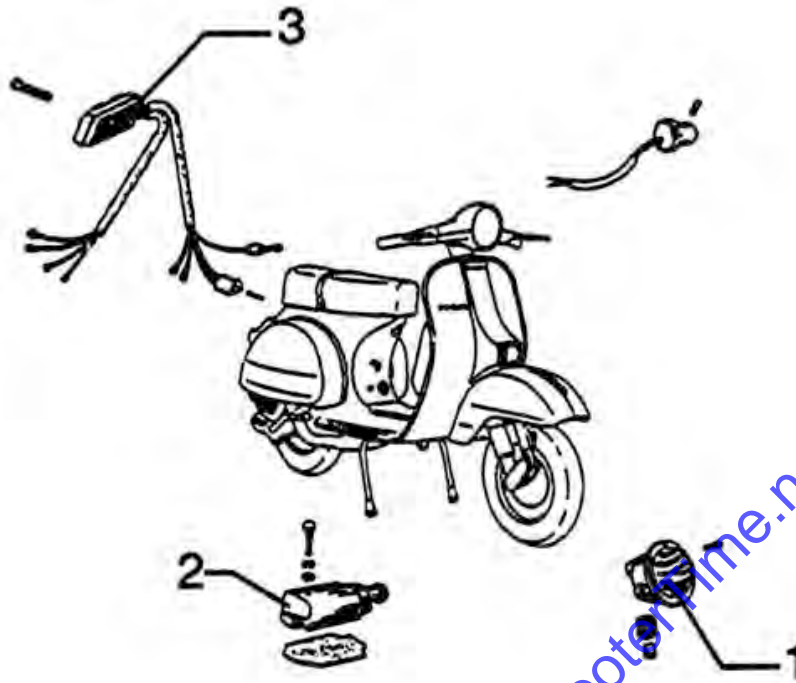

ELECTRICAL DEVICES

	Code	Action	Duration
1	005003	Horn - Replacement	
2	005017	Stop light switch - Replacement	
3	005069	LHS switch - Replacement	

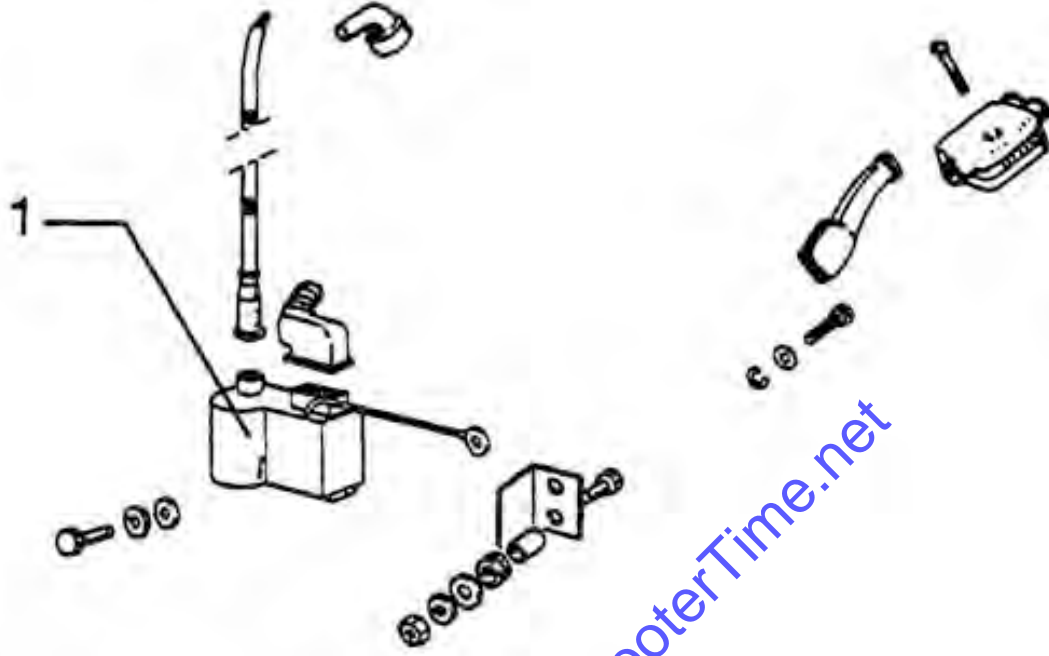

ECU - CDI

	Code	Action	Duration
1	001023	CDI - Replacement	

Transmissions

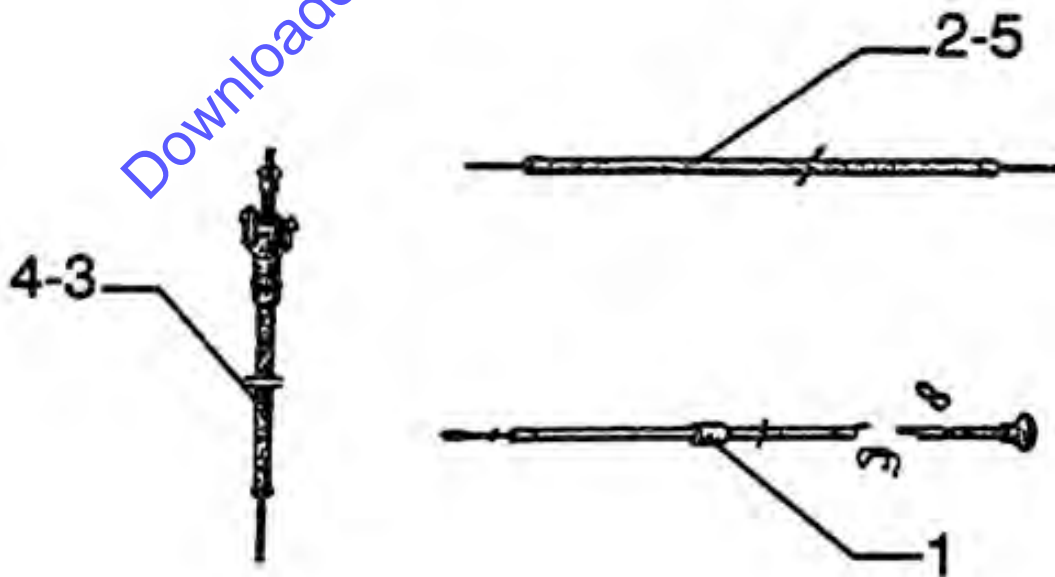

CABLES

	Code	Action	Duration
1	002008	Choke cable - Replacement	
2	002056	Gear shifter cable assy. - Replacement	
3	002051	Odo/Speedometer cable assy. - Replacement	
4	002049	Odo/Speedometer cable - Replacement	
5	002046	Gear shifter cable - Replacement	

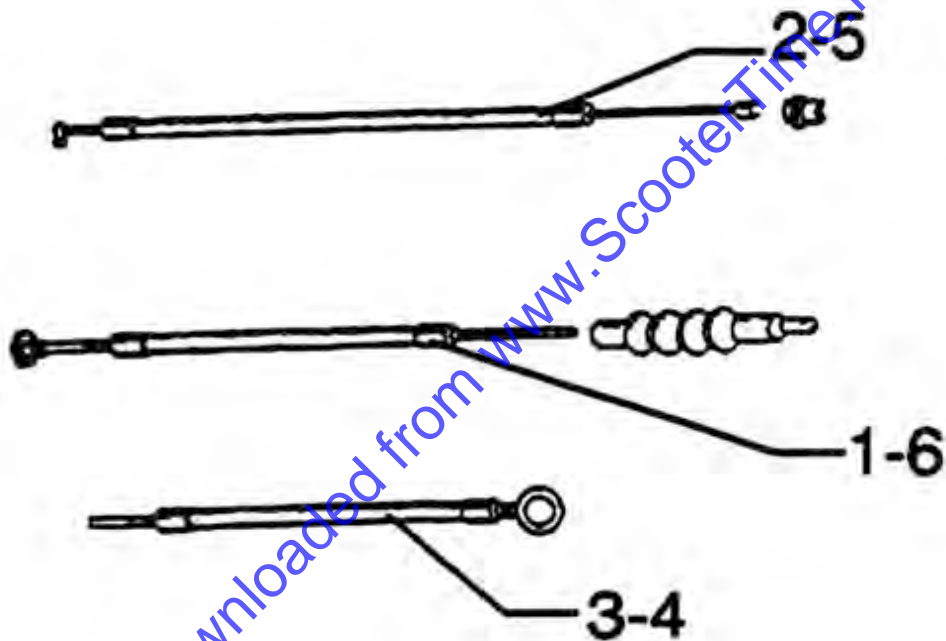

CABLES

	Code	Action	Duration
1	002055	Clutch cable assy. - Replacement	
2	002063	Throttle cable assy. - Replacement	
3	002053	Rear brake cable assembly - Replacement	
4	003060	Rear brake cable - Adjustment	
5	003061	Throttle cable - Adjustment	
6	002045	Clutch cable - Replacement	

Brake callipers

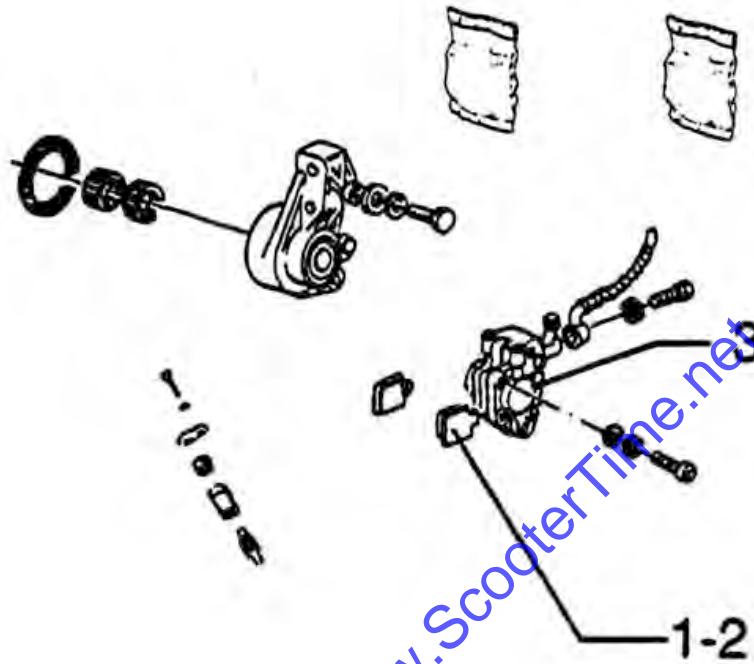

BRAKE CALLIPERS

	Code	Action	Duration
1	003070	Front brake pads - wear check	
2	002007	Front brake pads - Removal and refitting	
3	002039	Front brake calliper - Removal and refitting	

Steering column

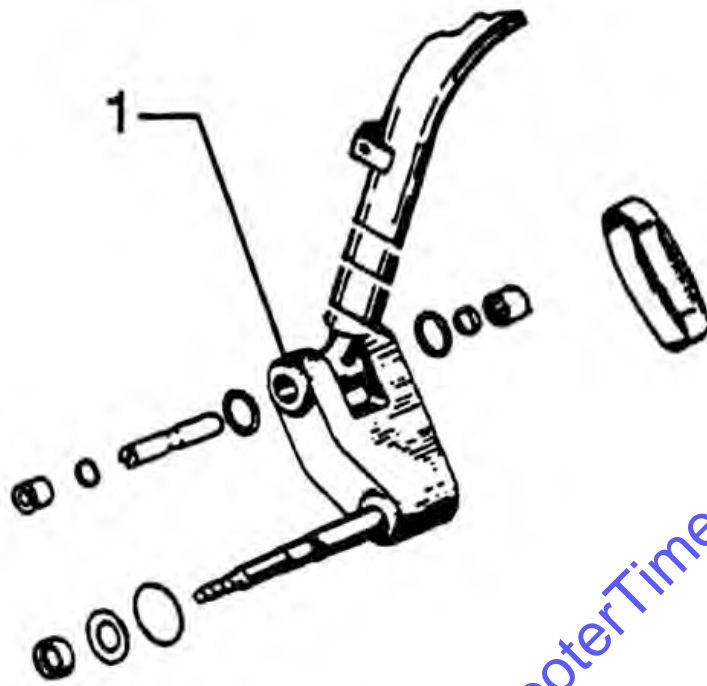

STEERING COLUMN

	Code	Action	Duration
1	003010	Front suspension - Overhaul	

Front suspension

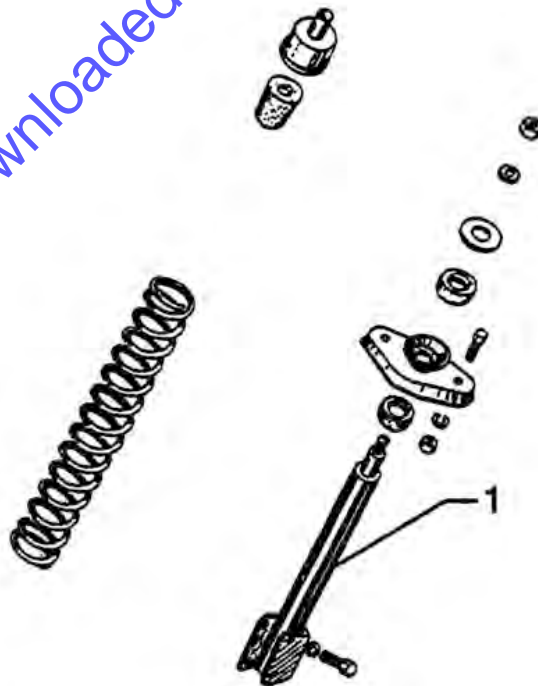

FRONT SHOCK-ABSORBER

	Code	Action	Duration
1	003011	Front shock absorber - Removal and refitting	

Braking system

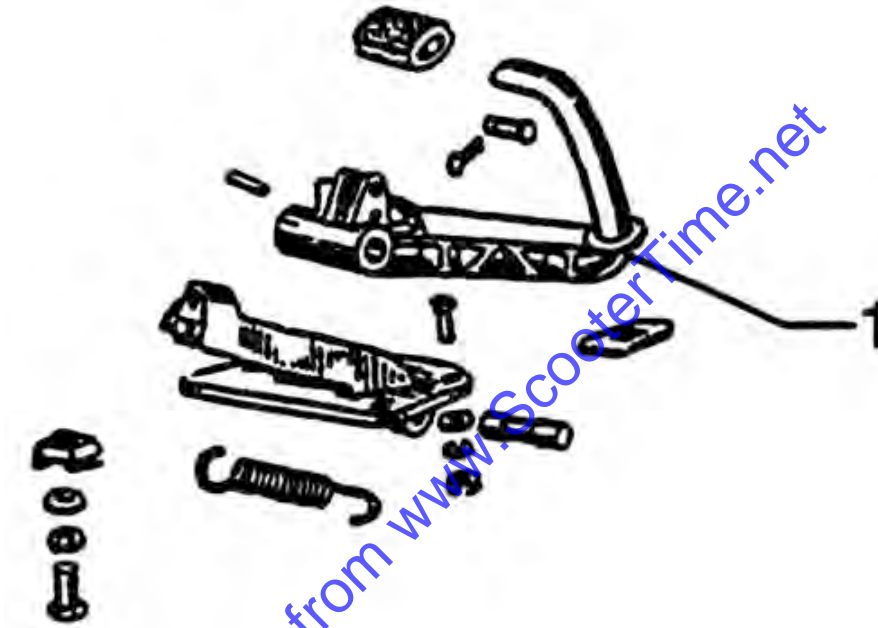

REAR BRAKE PEDAL

	Code	Action	Duration
1	002014	Brake pedal - Removal and refitting	

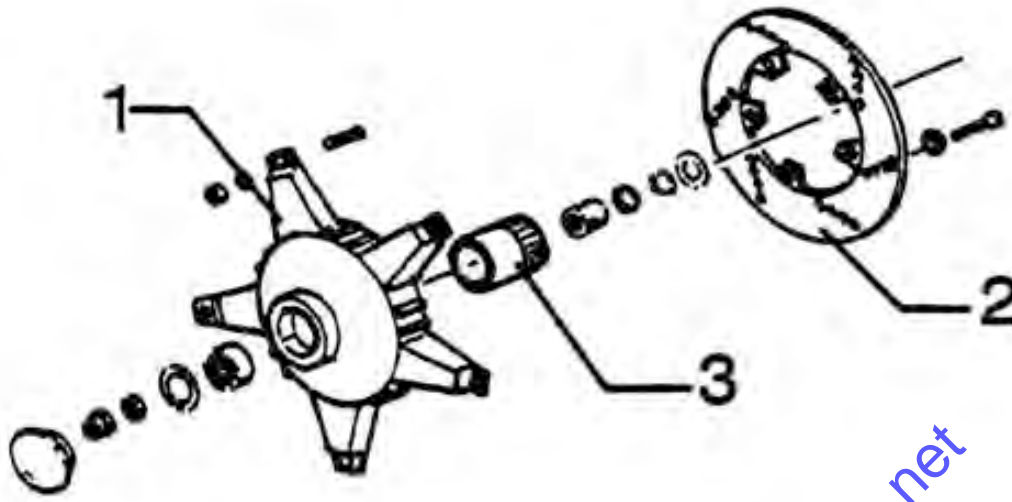

FRONT WHEEL HUB

	Code	Action	Duration
1	003033	Front wheel hub - Replacement	
2	002041	Brake disc - Replacement	
3	003040	Front wheel bearings - Replacement	

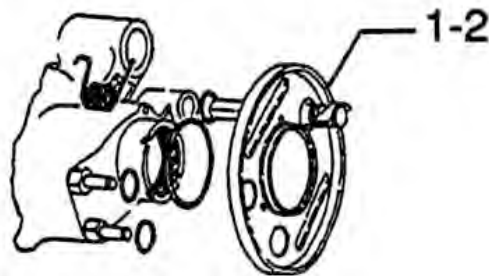
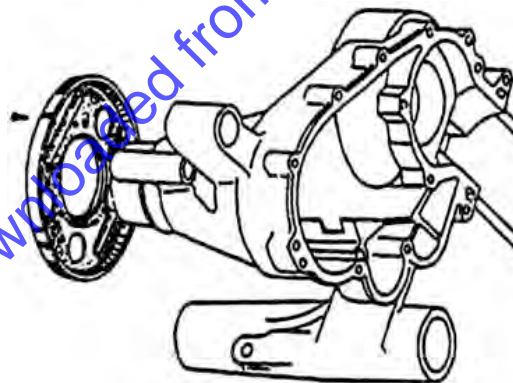

SHOE PLATE

	Code	Action	Duration
1	002016	Rear brake shoe plate - Replacement	
2	003012	Brake shoe plate - Removal and Refitting	

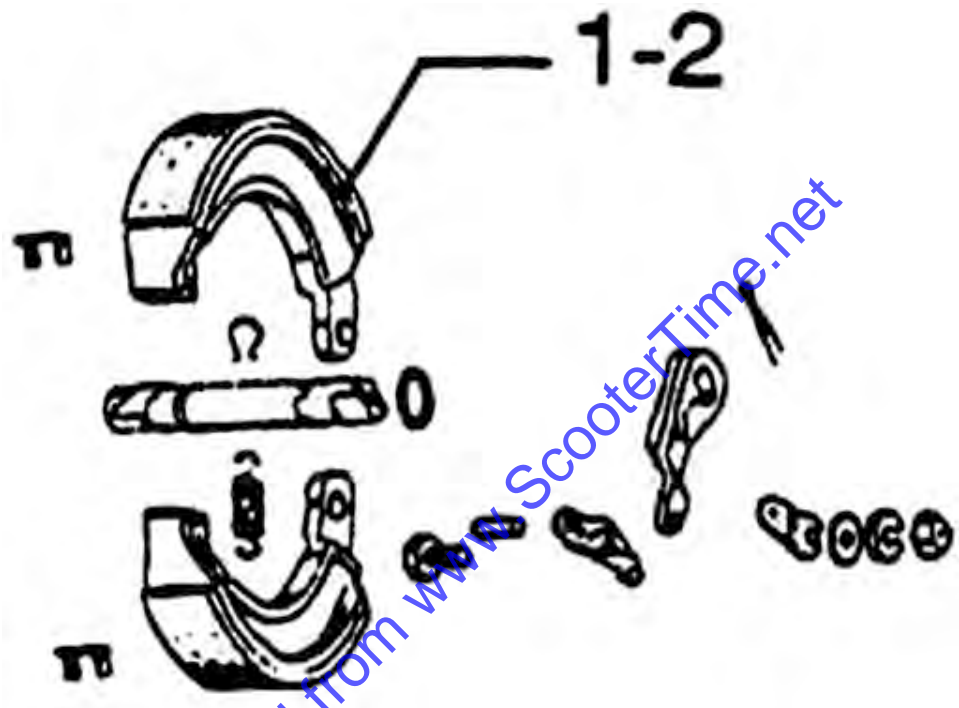

REAR BRAKE SHOES

	Code	Action	Duration
1	002002	Rear brake shoe(s) - Replacement	
2	003071	Rear brake shoe(s) - Wear check	

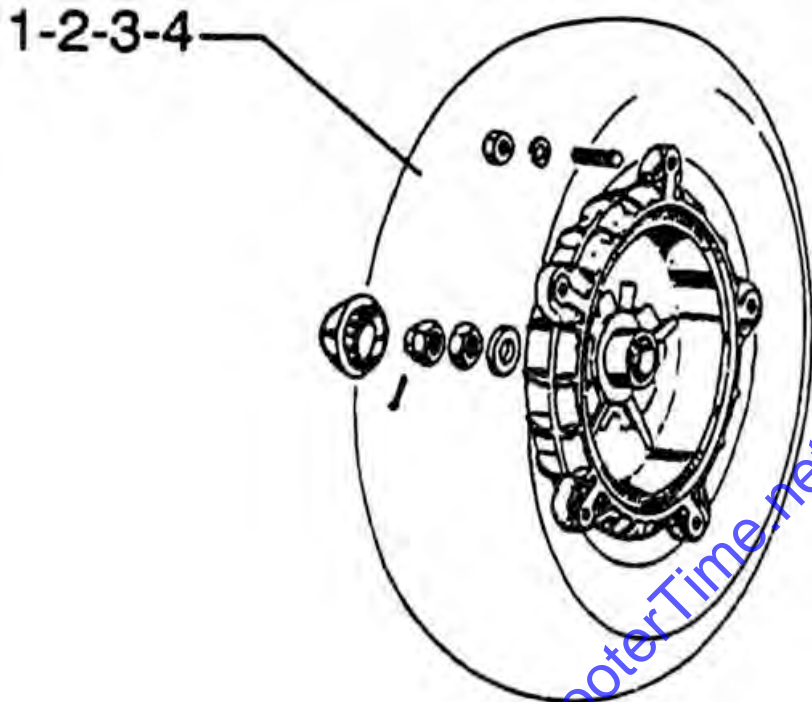

REAR BRAKE DRUM

	Code	Action	Duration
1	002010	Rear brake drum - Replacement	
2	001016	Rear wheel - Replacement	
3	004026	Handlebar cover - Replacement	
4	001071	Rear wheel rim - Removal and refitting	

Clutch cover

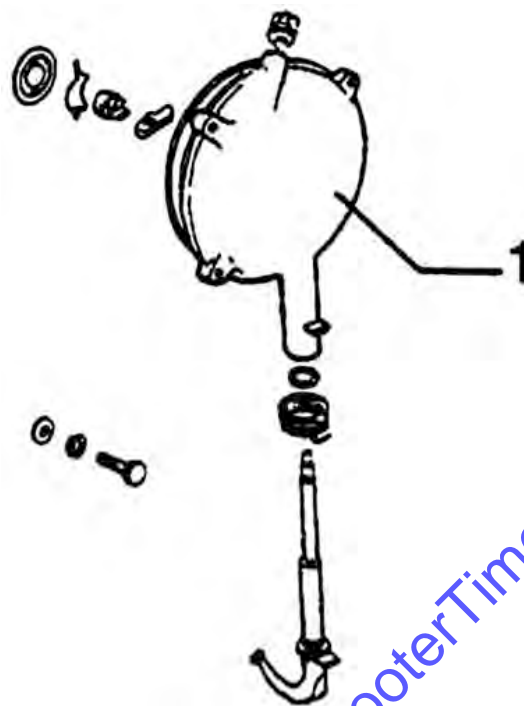

CLUTCH COVER

	Code	Action	Duration
1	001073	Clutch cover - Removal and refitting	

Clutch

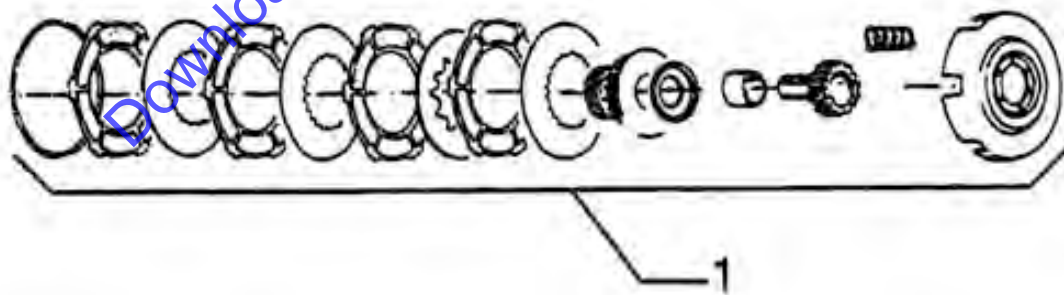

CLUTCH

	Code	Action	Duration
1	001022	Clutch - Removal	

Gear-box

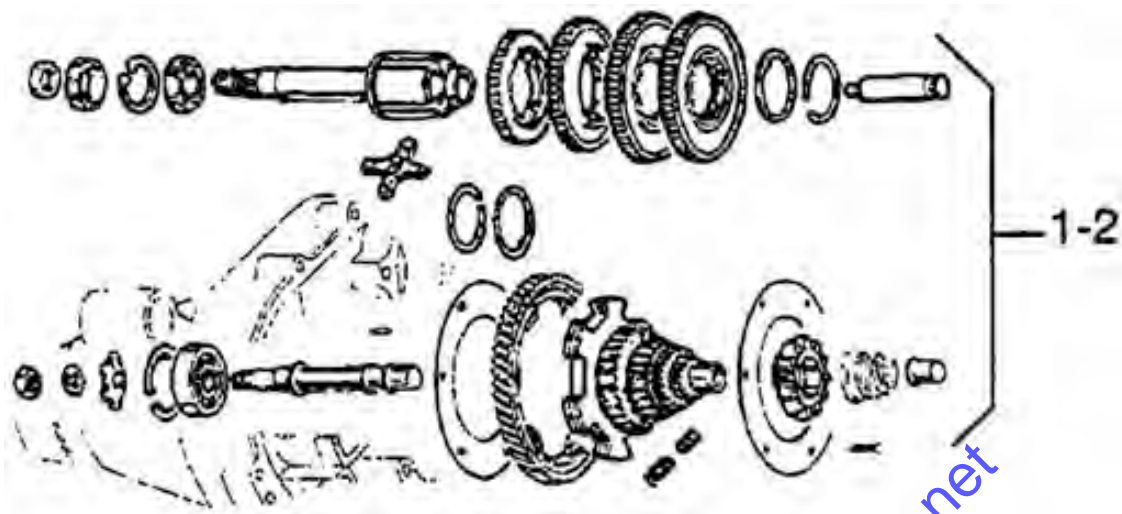

GEAR-BOX

	Code	Action	Duration
1	001119	Gearbox components - Replacement	
2	001025	Gearbox - Overhaul	

Gear shifter

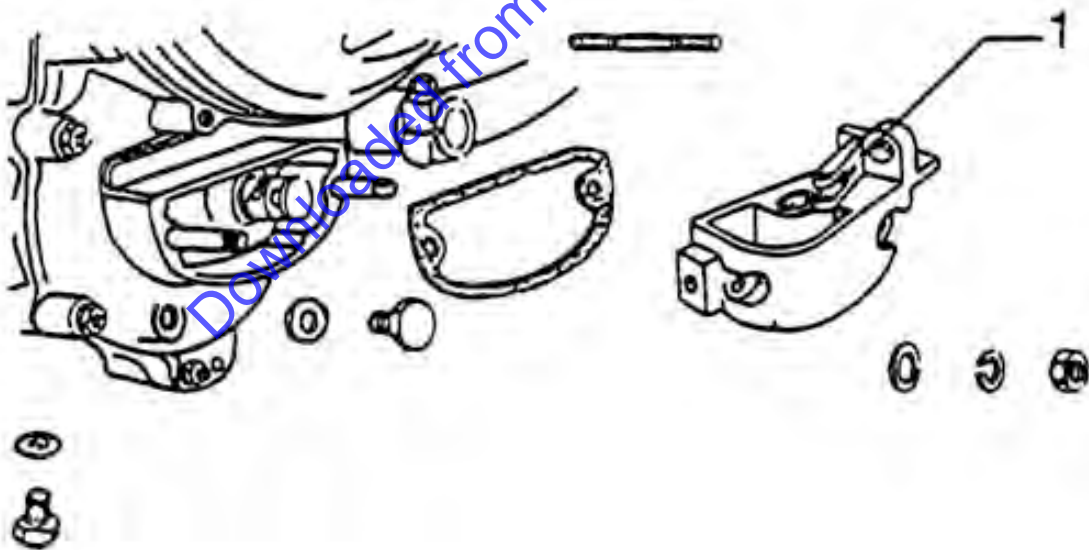

GEAR SHIFTER FASTENERS

	Code	Action	Duration
1	001077	Gear shifter components - Removal and refitting	

GEAR SHIFTER

	Code	Action	Duration
1	001029	Gear shifter - Overhaul	



Downloaded from www.ScooterTime.net