

Vespa would like to thank you

for choosing one of its products. We have prepared this manual to help you to get the very best from your scooter. Please read it carefully before riding the scooter for the first time. It contains information, tips and precautions for using your scooter. It also describes features, details and devices to assure you that you have made the right choice. We believe that if you follow our suggestions, you will soon get to know your new vehicle and it will serve you well for a long time to come. This booklet forms an integral part of the scooter; should the scooter be sold, it must be transferred to the new owner.

Vespa GTV 250 i.e.



The instructions given in this manual are intended to provide a clear, simple guide to using your scooter; details are also given of routine maintenance procedures and regular checks that should be carried out on the vehicle at an **Authorised PIAGGIO Dealer or Service Centre**. The booklet also contains instructions for simple repairs. Any operations not specifically described in this manual require the use of special tools and/or particular technical knowledge: to carry out these operations refer to any **authorised PIAGGIO Dealer or Service Centre**.



Personal safety

Failure to completely observe these instructions will result in serious risk of personal injury.



Safeguarding the environment

Sections marked with this symbol indicate the correct use of the vehicle to prevent damaging the environment.



Vehicle intactness

The incomplete or non-observance of these regulations leads to the risk of serious damage to the vehicle and sometimes even the invalidity of the guarantee.

The signs that you see on this page are very important. They are used to highlight those parts of the booklet that should be read with particular care. As you can see, each sign consists of a different graphic symbol, making it quick and easy to locate the various topics.

INDEX

VEHICLE	7	Stand.....	28
Dashboard.....	8	Automatic transmission.....	29
Analogue instrument panel.....	8	Safe driving.....	29
Clock.....	9	Rear rack.....	31
Setting the total and trip odometers.....	9	MAINTENANCE	33
Key switch.....	9	Engine oil level.....	34
Locking the steering wheel.....	9	Engine oil level check.....	34
Releasing the steering wheel.....	10	Engine oil top-up.....	34
Switch direction indicators.....	10	Warning light (insufficient oil pressure).....	34
Horn button.....	11	Engine oil change.....	35
Light switch.....	11	Hub oil level.....	36
Start-up button.....	11	Tyres.....	38
Engine stop button.....	12	Spark plug dismantlement.....	39
The immobilizer system.....	12	Removing the air filter.....	40
Keys.....	12	Cooling fluid level.....	41
Immobilizer device enabled indicator led.....	13	Checking the brake oil level.....	43
Operation.....	13	Battery.....	44
Programming the immobilizer system.....	14	Use of a new battery.....	45
Accessing the fuel tank.....	15	Long periods of inactivity.....	46
The saddle.....	16	Fuses.....	47
Opening the saddle.....	17	Front light group.....	50
Identification.....	18	Headlight adjustment.....	51
Rear top box opening.....	19	Front direction indicators.....	52
USE	21	Rear optical unit.....	53
Checks.....	22	Rear turn indicators.....	53
Refuelling.....	22	Rear-view mirrors.....	53
Tyre pressure.....	24	Front and rear disc brake.....	54
Shock absorbers adjustment.....	25	Puncture.....	55
Running in.....	26	Periods of inactivity.....	56
Starting up the engine.....	26	Cleaning the vehicle.....	56
Precautions.....	27	TECHNICAL DATA	61
Difficult start up.....	27	Kit equipment.....	65
Stopping the engine.....	28	SPARE PARTS AND ACCESSORIES	67

Warnings.....	68
PROGRAMMED MAINTENANCE.....	71
Scheduled maintenance table.....	72

Vespa GTV 250 i.e.

Vespa®



**Chap. 01
Vehicle**

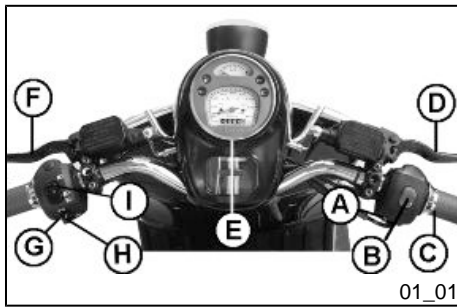

Dashboard (01_01)

- A = Starter button
- B = Engine block Run-Off switch
- C = Throttle control
- D = Front brake lever
- E = Instrument panel
- F = Rear brake control lever
- G = Horn button
- H = Turn indicator switch
- I = Light switch

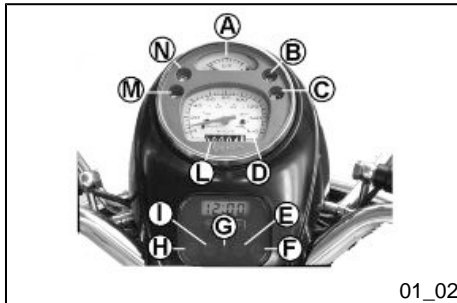

Analogue instrument panel (01_02)

- A = Fuel gauge
- B = Headlight warning light
- C = High-beam warning light
- D = Speedometer
- E = ABS Warning light (wiring)
- F = Coolant temperature warning light
- G = Antitheft device Led (immobilizer)
- H = Engine control telltale light and injection system failure warning light
- I = Turn indicator warning light
- L = Odometer
- M = Low oil pressure warning light
- N = Low fuel warning light

Clock (01_03)

Located on the instrument panel, it displays hours and minutes with 1 to 24 hour time. Besides hours and minutes, month and day can also be displayed with the «T» button. In order to adjust the above mentioned functions, operate button «U».



01_03

Setting the total and trip odometers (01_04)

The «TRIP» button displays the total and partial kilometres covered when pressed repeatedly for less than 1 second. It resets the trip odometer when pushed more than 3 seconds. Push the «TRIP» button again to return to total odometer value.

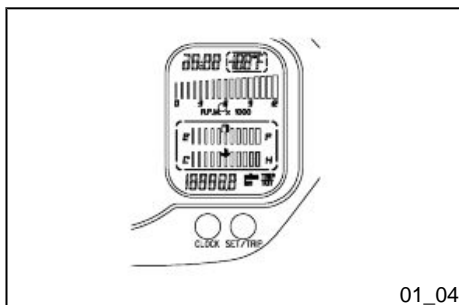

01_04

Key switch (01_05)

LOCK = ignition disabled, extractable key, mechanical antitheft device enabled.

OFF = ignition disabled, extractable key, mechanical antitheft device disabled.

ON = Ready to ignition position, non-extractable key, mechanical antitheft device disabled, lights on.

Locking the steering wheel

Turn the handlebar to the left (as far as it will go), turn the key to position «**LOCK**» and remove the key.



01_05

CAUTION

DO NOT TURN THE KEY TO «LOCK» OR «OFF» WHILE RIDING.

Releasing the steering wheel

Reinsert the key and turn it to «OFF».

CAUTION

DO NOT TURN THE KEY TO «LOCK» OR «OFF» WHILE RIDING.

Switch direction indicators (01_06)

Lever towards "S" = Left turn indicator is switched on;

Lever towards "D" = Right turn indicator is switched on;

The lever returns automatically to position "0" and the turn indicator "B" remains on; press the lever to turn them off.

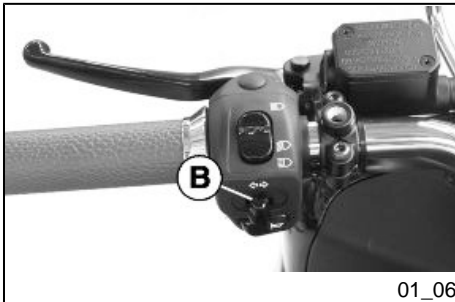

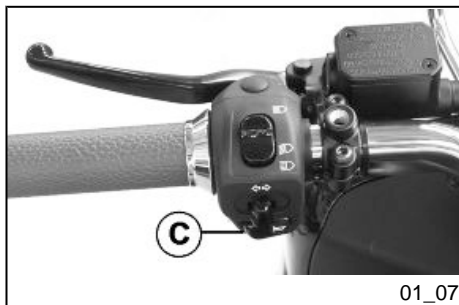

Horn button (01_07)

Push the «C» button to sound the horn.

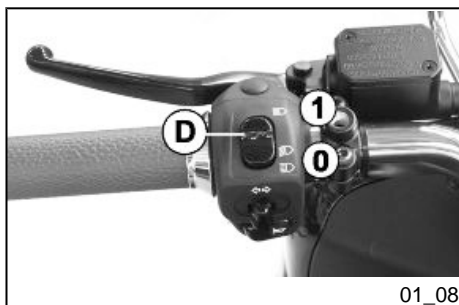

Light switch (01_08)

0 = Low beam and side light

1 = High beam and side light



Start-up button (01_09)

Starter button "G"

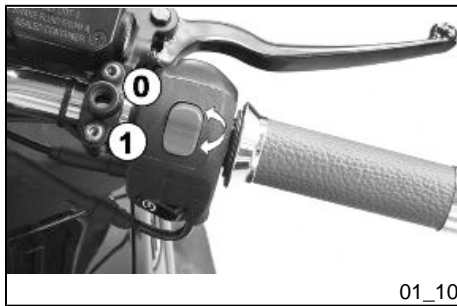

01_10

Engine stop button (01_10)

0 = OFF

1 = RUN

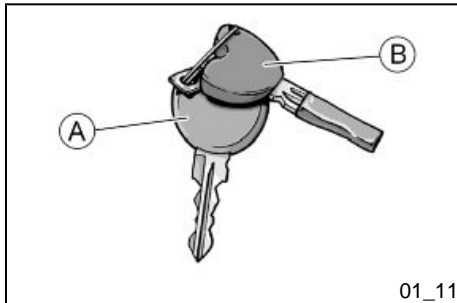

01_11

The immobilizer system

In order to enhance theft protection, the scooter is equipped with a «**PIAGGIO IMMOBILIZER**» electronic engine locking device that is activated automatically when the starter key is removed. Upon start-up, the «**PIAGGIO IMMOBILIZER**» system checks the starter key, and only if this key is recognised will the immobilizer system allow the scooter to be started.

Keys (01_11, 01_12, 01_13)

Two types of keys come with the vehicle.

The red-handgrip key "A" is the "**MASTER**" key.

Only a single copy of this key is supplied, which is necessary to program all your other keys and for your dealer to perform some maintenance operations. For this reason it is advised that it be used only in exceptional circumstances.

The blue key «**B**» (single copy supplied) is used for normal operations such as:

- engine start up
- glove-box opening

Together with the two keys, you will be given a CODE CARD bearing the same code imprinted onto the two keys.

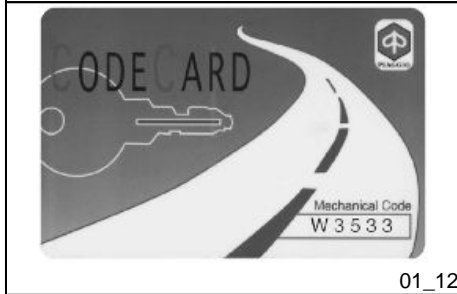

01_12

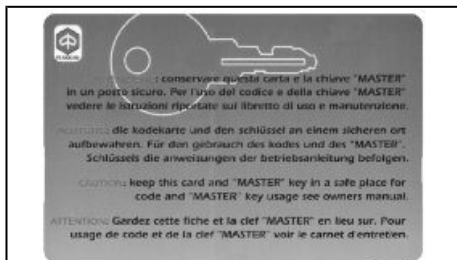

01_13



01_14

WARNING

LOSING THE RED KEY PREVENTS ANY REPAIRS OF THE "PIAGGIO IMMOBILIZER" SYSTEM AND THE ENGINE CONTROL UNIT.

WARNING

KEEP THE "CODE CARD" AND THE RED HANDGRIP KEY IN A SAFE PLACE (NOT ON YOUR VEHICLE).

Immobilizerdevice enabled indicator led (01_14)

Activation of the «PIAGGIO IMMOBILIZER» system is signalled by a flashing red warning light.

To reduce battery discharge, the indicator led turns off automatically after 48 hours of uninterrupted functioning.

Should the system fail, different LED flashing patterns will be provided by an **Authorised Piaggio-Gilera Service Centre** with information on the type of fault detected.

Operation

Every time the starter key is removed in the "OFF" or "LOCK" position, the safety system activates the immobilizer system. Turning the key to "ON" disables the engine lock, provided that the safety system recognises the code transmitted by the key. If the code is not recognised, turn the key first to "OFF" and then to "ON"; if the lock cannot be disabled, try with the other key supplied (red-coloured). If the engine cannot be started, contact an **Authorised Piaggio Service Centre**, which is provided with the electronic equipment required to detect and repair the system.

When additional keys are required, please note that data storage (up to 7 keys max.) must be done on all keys, both new ones and existing ones.

Take your scooter to an **Authorised Piaggio Service Centre** carrying with you the red-handgrip key and all the blue keys in your possession.

The codes of keys not submitted for the new storage procedure are deleted from the memory. Any lost keys will therefore not be enabled to start the engine.

WARNING



EACH KEY HAS ITS OWN AND UNIQUE CODE, WHICH MUST BE STORED BY THE SYSTEM CONTROL UNIT.

VIOLENT SHOCKS MAY AFFECT THE ELECTRONIC COMPONENTS OF THE KEY.

IF OWNERSHIP OF THE VEHICLE IS TRANSFERRED, THE RED-HANDGRIP KEY (AS WELL AS THE OTHER KEYS) AND THE "CODE CARD" MUST ALSO BE TRANSFERRED TO THE NEW OWNER.

Programming the immobilizer system

Below is described the procedure to follow for programming the **PIAGGIO IMMOBILIZER** system and/or for storing other key codes. The programming procedure should be carried out with the engine stop switch set to «**RUN**».

Procedure start - red key

Insert the red-handgrip key in the switch key (in "**OFF**" position) and turn it to "**ON**". After 1 - 3 seconds, turn the key to "**OFF**" again and pull it out.

Intermediate step - blu key

Within ten seconds after pulling out the red key, insert the black key and promptly turn it to «**ON**». After 1-3 seconds, turn the key to "**OFF**" again and pull it out.

In this way, a maximum of 3 blue keys can be programmed by repeating the above procedure and keeping the indicated times.

Final step - red key

After pulling out the last blue key, insert the red key again and turn it to "ON" (this operation should be performed within 10 seconds of pulling out the previous key). Leave it in this position for 1 to 3 seconds and return it to the «OFF» position.

Proper programming check

Insert the red key disabling the transponder (i.e., tilt the key cap by 90°) and turn the key to "ON". Perform the engine start-up operation. Ensure that the engine does not start. Insert the blue key and repeat the start-up operation. Check that engine starts.

WARNING

SHOULD THE ENGINE START WITH THE RED KEY (WITH TRANSPONDER OFF), OR IN THE EVENT OF WRONG OPERATION DURING PROGRAMMING, REPEAT THE PROCEDURE FROM THE BEGINNING.

Accessing the fuel tank (01_15, 01_16, 01_17)

With the key set to «OFF» or «ON», or with engine on, it is possible to electrically open the saddle by pressing the button «C». If the saddle opening system does not work, operate the emergency lever «A». Then, unscrew cap «B» and the fuel tank can be reached.

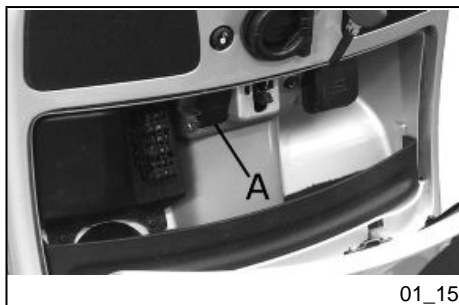



01_16

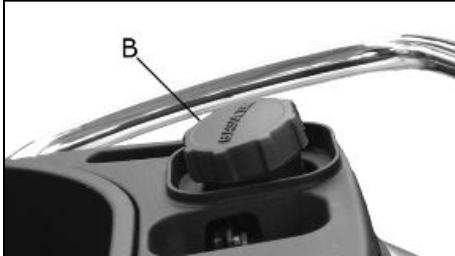

01_17



01_18

The saddle (01_18)

Saddles fitted to this scooter are upholstered in Authentic Leather, and are a stylish accessory to emphasise an already exclusive product such as your Vespa. As leather is a natural and vivid material, it tends to get "very opaque" aspect as time goes by, an aspect typical of Authentic Leather. This product may also show characteristic undertones and strains.

To care and maintain the features of the saddle through time, follow these tips: Do not expose it to weather changes, when the scooter is parked protect it with the waterproof cover supplied and stored under the saddle.

Periodically, especially during rainy seasons, apply commercially available waterproofing products (footwear spray). Do not apply shoe polish or wax on the saddle so as not to stain your clothes.



01_19

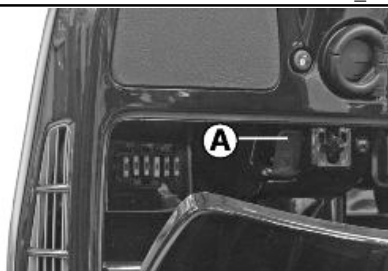

01_20

In case of forced and prolonged exposure to water, dry the saddle far from any heat source, do not use alcohol, solvent-based products and pay special care when refuelling.

If the saddle gets stained, wipe the area and if necessary wash it with lukewarm water and neutral soap.

WARNING



DUE TO THE SPECIAL SADDLE STRUCTURE AND COVER CHARACTERISTICS, USE THE SUPPLIED WATERPROOF PROTECTION, PLACED UNDER THE SADDLE, EVERY TIME THE SCOOTER HAS TO BE PARKED IN THE OPEN FOR A LONG TIME.

Opening the saddle (01_19, 01_20, 01_21, 01_22)

With the key set to «OFF» or «ON», or with engine on, it is possible to electrically open the saddle by pressing button «C». If the electric opening does not work, use the emergency lever "A". When the key is set to "LOCK" the saddle cannot be opened.

WARNING



DUE TO THE SPECIAL SADDLE STRUCTURE AND COVER CHARACTERISTICS, USE THE SUPPLIED WATERPROOF PROTECTION, PLACED UNDER THE SADDLE, EVERY TIME THE SCOOTER HAS TO BE PARKED IN THE OPEN FOR A LONG TIME.



01_21

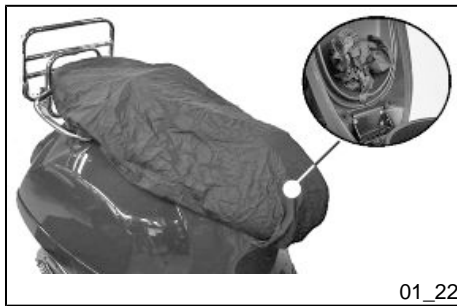

01_22

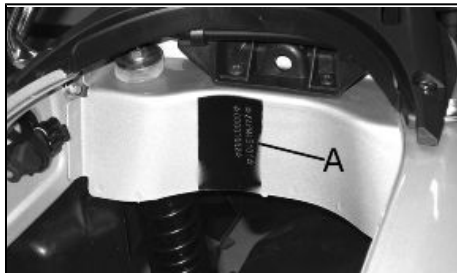

01_23

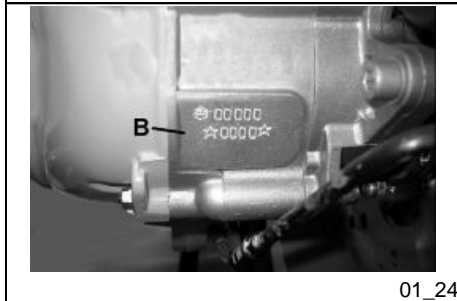

01_24

Identification (01_23, 01_24, 01_25)

The identification registration numbers consist of a prefix followed by a number stamped on both the chassis «A» and the engine «B». These numbers must always be indicated on spare parts requests. To read the chassis number, lift the saddle and remove the helmet compartment «C». We recommend checking that the chassis registration number stamped on the scooter corresponds with that on the scooter's documents.

CAUTION



BE REMINDED THAT ALTERING IDENTIFICATION REGISTRATION NUMBERS CAN LEAD TO SERIOUS PENAL SANCTIONS (IMPOUNDING OF THE VEHICLE, ETC.).

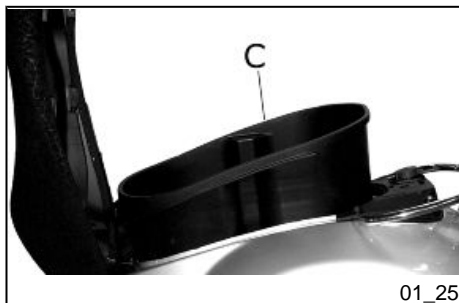

Rear top box opening (01_26, 01_27)

Insert the key into the switch and press down until the glove compartment opens. If the switch is set to "LOCK", turn the key to "OFF" or "ON" before pressing it down.

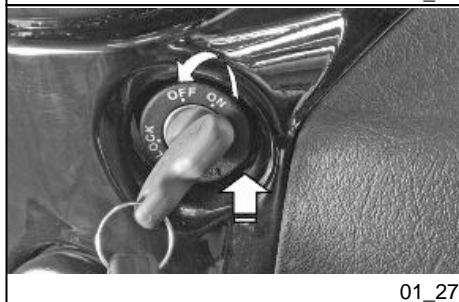

Vespa GTV 250 i.e.

Vespa®



Chap. 02
Use

Checks

Before using the vehicle, check:

1. There is enough fuel in the fuel tank.
2. The correct fluid level for front and rear brakes.
3. That tyres are properly inflated.
4. The correct functioning of tail lights, headlamp, turn indicators, stop light and license plate light.
5. The correct functioning of front and rear brakes.
6. The oil level in the gearcase.
7. The engine oil level.
8. The coolant level.

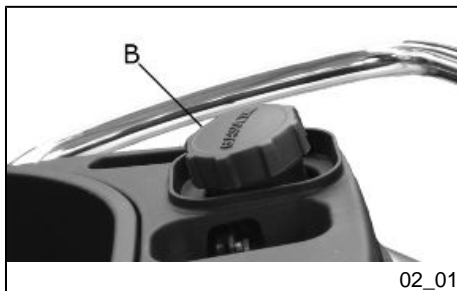

Refuelling (02_01, 02_02)

Fuel: lift the saddle and unscrew the cap «**B**». Recommended fuel: Unleaded petrol (95 octane min.). The fuel reserve level is signalled when the warning light «**N**» turns on.

WARNING



SWITCH OFF THE ENGINE BEFORE REFUELLING WITH PETROL.

PETROL IS HIGHLY INFLAMMABLE.

DO NOT SMOKE AND KEEP OPEN FLAMES AT A DISTANCE:FIRE HAZARD.

DO NOT INHALE FUEL FUMES.

DO NOT ALLOW PETROL TO COME INTO CONTACT WITH HOT ENGINE OR ANY PLASTIC PARTS.

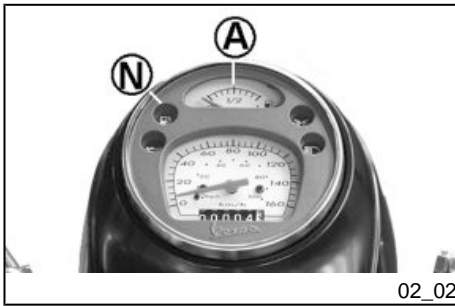

02_02

CAUTION



PETROL DAMAGES THE PLASTIC PARTS OF THE BODYWORK.

CAUTION



USING OILS OTHER THAN THOSE RECOMMENDED CAN SHORTEN THE LIFE OF THE ENGINE.

CAUTION



DO NOT USE THE VEHICLE TO THE COMPLETE EXHAUSTION OF THE FUEL; IN THE EVENT THAT THIS SHOULD OCCUR, DO NOT ATTEMPT TO START THE ENGINE. TURN THE KEY SWITCH TO OFF AND TOP-UP THE TANK AS SOON AS POSSIBLE. FAILURE TO FOLLOW THESE GUIDELINES COULD DAMAGE THE FUEL PUMP AND/OR THE CATALYTIC CONVERTER.

Characteristic

Fuel tank capacity

~ 9.2 litres

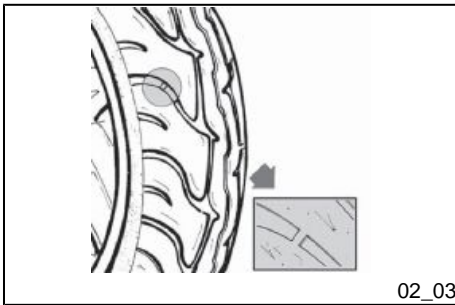

Tyre pressure (02_03)

Check the tyre pressure and wear periodically (roughly every 500 km). The tyres are equipped with wear indicators; the tyres should be replaced as soon as these indicators become visible on the tyre tread. Also check that tyres do not show cuts on the sides or irregular tread wear; if this occurs, go to an authorised workshop or at least a workshop equipped to perform the replacement.

CAUTION



TYRE PRESSURE SHOULD BE CHECKED WHEN TYRES ARE COLD. INCORRECT TYRE PRESSURE CAUSES ABNORMAL TYRE WEAR AND MAKES RIDING DANGEROUS.

TYRES MUST BE REPLACED WHEN THE TREAD REACHES THE WEAR LIMITS SET FORTH BY LAW.

Characteristic

Front tyre pressure

1.8 bar

Rear tyre pressure

2 bar

Rear tyre pressure - driver and passenger

2.2 bar

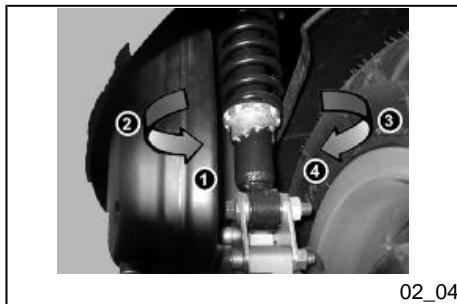

02_04

Shock absorbers adjustment (02_04)

The preloading of the springs can be adjusted to 4 positions using the ring nut located in the lower part of the shock absorbers and the specific spanner supplied.

Position 1: Minimum preload: driver only

Position 2 medium preloading: driver only

Position 3 medium preloading: rider and passenger

Position 4: Maximum preload: driver, passenger, and luggage.

In order to carry out this operation you will need to use the specific spanner in the kit.

CAUTION



RIDING THE VEHICLE WITH THE SPRING PRELOADING NOT CORRECTLY SET FOR THE RIDER AND POSSIBLE PASSENGER, COULD REDUCE THE COMFORT OF THE RIDE AND THE PRECISION OF THE STEERING.

WARNING



WE RECOMMEND WEARING GLOVES WHILE CARRYING OUT THIS OPERATION IN ORDER TO AVOID INJURIES.

WARNING



WE STRONGLY RECOMMEND NOT TO ADJUST BOTH SHOCK ABSORBERS WITH DIFFERENT PRELOADING



02_05

Running in (02_05)

WARNING



DURING THE FIRST 1000 KM DO NOT RIDE THE VEHICLE OVER 80% OF ITS MAXIMUM SPEED. AVOID TWISTING THE THROTTLE GRIP FULLY OR KEEPING A CONSTANT SPEED ALONG LONG SECTIONS OF ROAD. AFTER THE FIRST 1000 KM, GRADUALLY INCREASE SPEED UNTIL REACHING THE MAXIMUM PERFORMANCE.



02_06

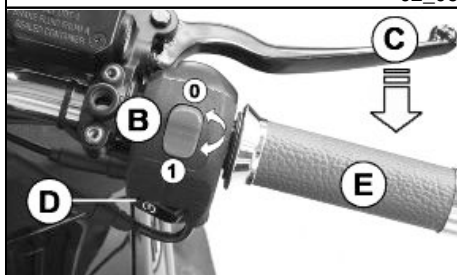

02_07

Starting up the engine (02_06, 02_07)

To start the engine it is necessary, before pressing the starter button, to pull and keep pulled the front or rear brake lever, which activates the appropriate switch allowing start-up.

1. Rest the vehicle on its centre-stand, ensuring the rear wheel is not touching the ground.
2. Maintain the throttle grip «E» completely untwisted.
3. Insert the key into the ignition switch «A» and turn to position «ON».
4. Make sure that switch «B» "0-1" is set to "1".
5. Pull lever «C» of the front or rear brake and then activate the starter button «D».

WARNING



THE AUTOMATIC TRANSMISSION MAKES THE REAR WHEEL TURN EVEN WHEN THE THROTTLE IS SLIGHTLY TWISTED. RELEASE THE BRAKE CAREFULLY AFTER STARTING, AND THEN ACCELERATE GRADUALLY.

CAUTION

DO NOT START-UP THE ENGINE IN CLOSED AREAS BECAUSE EXHAUST GASES ARE TOXIC.

Precautions**CAUTION**

NEVER STRESS THE ENGINE AT LOW TEMPERATURES IN ORDER TO AVOID POSSIBLE DAMAGE. BE CAREFUL NEVER TO EXCEED THE MAXIMUM SPEED WHILE RUNNING DOWNHILL, IN ORDER TO AVOID DAMAGING THE ENGINE. IN ANY CASE, IN ORDER TO PRESERVE THE ENGINE FROM PROLONGED EXCESSIVE REVOLUTIONS, THE REVOLUTION LIMITER WILL BE ACTIVATED IF THE ENGINE SPEED EXCEEDS THE ESTABLISHED THRESHOLD.

WARNING

AFTER A LONG DISTANCE COVERED AT THE MAXIMUM SPEED, DO NOT STOP THE ENGINE IMMEDIATELY, BUT LET IT RUN AT IDLE FOR A FEW SECONDS.

Difficult start up

In the rare case of flooding the engine, to facilitate start-up, it is possible to try to put the vehicle into action with the gas hand grip partially or completely open. It is however necessary, once the engine is started, to take your vehicle to an **Authorised Service Centre** to determine the cause of this problem and to re-establish the vehicle proper functioning.



02_08

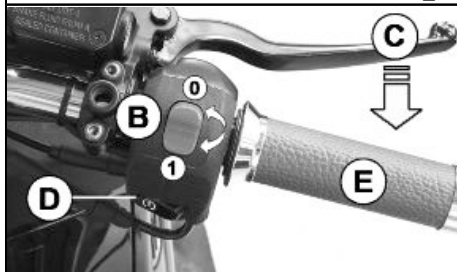

02_09

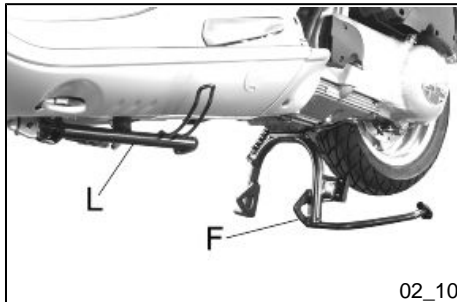

02_10

Stopping the engine (02_08, 02_09)

Fully untwist the throttle grip and then turn the switch key «A» to «OFF» (extractable key), or turn the switch «B» to «0».

CAUTION



DUE TO THE HIGH TEMPERATURES THE CATALYTIC CONVERTER CAN REACH, ALWAYS TAKE CARE, WHEN PARKING THE SCOOTER, THAT THE EXHAUST DOES NOT COME INTO CONTACT WITH FLAMMABLE MATERIALS, TO AVOID SERIOUS BURNS.

CAUTION



DO NOT SWITCH OFF THE ENGINE WHILE THE VEHICLE IS MOVING. UNBURNED FUEL COULD ENTER THE CATALYTIC CONVERTER AND BURN, CAUSING IT TO OVERHEAT AND POSSIBLY DESTROYING IT.

Stand (02_10)

CENTRE STAND

With your foot push the projection of the centre stand «F » while lifting the vehicle backwards, holding onto the side handles.

SIDE STAND

Push the projection of the stand "L " with your foot in order to open it and at the same time lean the vehicle on you.

Automatic transmission (02_11)

To ensure simple, pleasurable riding, the vehicle is equipped with automatic transmission with regulator and centrifugal clutch. The system is designed to provide the best performance (acceleration and consumption) while riding on both flat roads and uphill.

If you have to stop on an uphill slope (traffic lights, traffic jam, etc.) **use only the brake to keep the vehicle still, leaving the engine running at idle speed. Using the engine to keep the vehicle still can cause the clutch to overheat, due to the friction of the clutch mechanism itself against the clutch bell.**

It is therefore recommended to avoid conditions of prolonged clutch slippage (other than those previously indicated) like driving uphill fully laden on steep slopes or starting off with driver and passenger at slopes with steepness greater than 25%.

Observe the following precautions if the clutch overheats:

1. Do not continue riding in such conditions.
2. Let the clutch cool down with the engine at idle speed for a few minutes.

Safe driving (02_12)

WARNING



SOME SIMPLE TIPS ARE PROVIDED BELOW THAT WILL ENABLE YOU TO USE YOUR SCOOTER ON A DAILY BASIS IN GREATER SAFETY AND WITH MORE PEACE OF MIND.

<

Your ability and your knowledge of the vehicle form the basis of safe riding. We recommend trying out the vehicle in traffic-free zones to get to know your vehicle completely.

ALWAYS DRIVE WITHIN YOUR LIMITS



02_11



02_12

1. Before riding off, remember to put on your helmet and fasten it correctly.
2. Reduce speed and ride cautiously on uneven roads.
3. Remember that after riding on a long stretch of wet road without using the brakes, the braking effect is initially lower. Given these conditions, it is a good idea to operate the brakes from time to time.
4. Do not brake hard on a wet surface, on dirt tracks or on any slippery road surface.
5. If you have to brake, use both brakes in order to divide the braking action between both wheels.
6. Avoid starting off by mounting the scooter while it is still resting on its stand. In any case, the rear wheel should not be turning when it comes into contact with the ground, in order to avoid abrupt departures.
7. If the vehicle is used on roads covered with sand, mud, snow mixed with salt, etc., clean the brake disc frequently with mild detergent in order to prevent abrasive substances from building up within the holes, which can result in early wear of the brake pads.
8. Any elaboration that modifies the vehicle's performances, such as tampering with original structural parts is strictly forbidden by law, and renders the vehicle not conforming to the approved type and therefore dangerous to ride.

CAUTION

DO NOT FORGET THAT DRIVING IN A STATE OF DRUNKENNESS, OR WHEN UNDER THE EFFECT OF DRUGS OR CERTAIN MEDICINES, CAN BE EXTREMELY DANGEROUS FOR ONESELF AND FOR OTHERS.

CAUTION

ANY CHANGES TO THE VEHICLE PERFORMANCE AS WELL AS ALTERATIONS TO ORIGINAL STRUCTURAL PARTS IS STRICTLY FORBIDDEN BY LAW, AND

RENDERS THE VEHICLE NO LONGER CONFORMING TO THE APPROVED TYPE AND DANGEROUS FOR RIDING.

Rear rack (02_13)

When riding without packages on the luggage racks, set the corresponding retainer latch "A" as shown in the photograph.

WARNING



Maximum admissible load: 6 kg

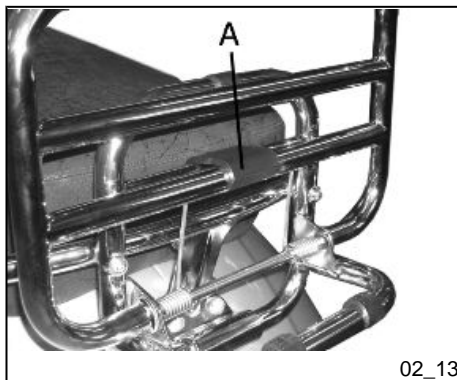

Vespa GTV 250 i.e.

Vespa®



**Chap. 03
Maintenance**



03_01



03_02

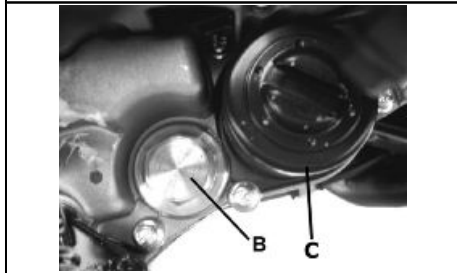

03_03

Engine oil level

In 4T engines, engine oil is used to lubricate the distribution elements, main bearings and thermal group. **An insufficient quantity of oil can cause serious damage to the engine itself.** In all four-stroke engines, a loss of efficiency in oil performance and consumption should be considered normal. Consumption can particularly reflect the conditions of use (i.e. when driving at "full acceleration" all the time, oil consumption increases). The replacement frequencies provided for by the maintenance programme are defined, depending on the total contents of oil in the engine and average consumption measured following standardised methods. **In order to prevent any problems, we recommend checking oil level more frequently than indicated in the Scheduled Maintenance table or before setting off on long journeys. The vehicle is, however, equipped with an oil pressure warning light on the instrument panel.**

Engine oil level check (03_01)

Every time the scooter is used, a visual check should be made on the level of the engine oil when the engine is cold. The oil level should be somewhere between the **MAX** and **MIN** index marks on the level bar; the check must be made with the scooter upright, resting on the centre stand. If the check is carried out after the vehicle has been used, and therefore with a hot engine, the level line will be lower; in order to carry out a correct check it is necessary to wait at least 10 minutes after the engine has been stopped, so as to get the correct level.

Engine oil top-up

Any topping up with oil must be carried out after the oil level check by adding oil, but **never exceeding the MAX level.** The topping up of the level between **MIN** and **MAX** requires approx. 200 cc of oil. Every 5000 km, however, the engine oil level should be checked and topped up, if necessary, at an **Authorised Piaggio Service Centre.**

Warning light (insufficient oil pressure)

The vehicle is equipped with a warning light that lights up when the key is turned to the «ON». However, this light should switch off once the engine has been started. **If the light comes on while braking, at idle speed or while turning a corner, it is necessary to check the oil level and top it up if required. If after having topped-**

up the oil, the warning light still comes on while braking, at idle speed or while turning a corner, it will be necessary to take your vehicle to an Authorised Service Centre.

Engine oil change (03_02, 03_03)

The oil and cartridge filter "C" must be changed after 1,000 km and every 10,000 km at an **authorised Piaggio service centre**. The engine should be emptied by draining the oil from the drainage cap "B" of the gauze filter on the flywheel side. In order to facilitate the oil drainage, loosen the cap/dipstick. Since a certain quantity of oil remains in the circuit still, the top-up should be carried out with around 600 ÷ 650 cc of oil from cap "A". Then start up the scooter, leave it running for a few minutes and switch it off: after five minutes, check the level and if necessary top up **without exceeding the MAX. level**. The cartridge filter must be replaced at every oil change. For top up and change, use new oil of the recommended type.

WARNING



RUNNING THE ENGINE WITH INSUFFICIENT LUBRICATION OR WITH INADEQUATE LUBRICANTS ACCELERATES THE WEAR AND TEAR OF THE MOVING PARTS AND CAN CAUSE IRRETRIEVABLE DAMAGE.

WARNING



EXCESSIVE OIL LEVEL AT TOP-UPS CAN LEAD TO SCALE FORMATION AND VEHICLE MALFUNCTIONING.

CAUTION



USED OILS CONTAIN SUBSTANCES HARMFUL TO THE ENVIRONMENT. FOR OIL REPLACEMENT, CONTACT AN AUTHORISED PIAGGIO SERVICE CENTRE,

AS THEY ARE EQUIPPED TO DISPOSE OF SPENT OILS IN AN ENVIRONMENTALLY FRIENDLY AND LEGAL WAY.

CAUTION



USING OILS OTHER THAN THOSE RECOMMENDED CAN SHORTEN THE LIFE OF THE ENGINE.

Recommended products

AGIP CITY HI TEC 4T

Engine oil

SAE 5W-40, API SL, ACEA A3, JASO MA Synthetic oil

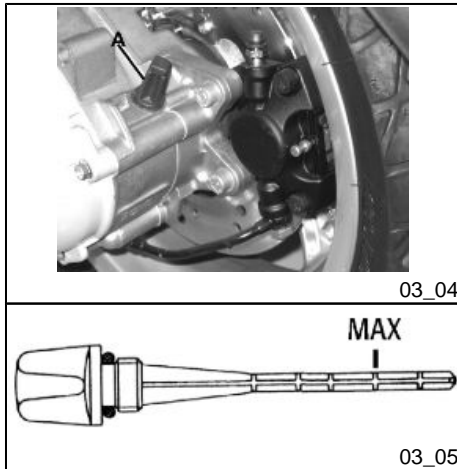

Hub oil level (03_04, 03_05)

Check the oil in the rear hub. To check the rear hub oil level, proceed as follows:

- 1) Park the scooter on level ground and rest it on its stand.
- 2) Unscrew dipstick "A", wipe it clean with a cloth, reinsert it and **tighten completely**.
- 3) Pull out the dipstick and check that the oil level is above the first notch from the bottom.
- 4) Reinsert the dipstick and ensure that it is tightened correctly.

N.B.

The notches on the hub oil level dipstick, except for the one indicating the "MAX" level, refer to other models by the manufacturer and have no specific function for this model.

CAUTION

RIDING THE VEHICLE WITH INSUFFICIENT HUB LUBRICATION OR WITH CONTAMINATED OR IMPROPER LUBRICANTS ACCELERATES THE WEAR AND TEAR OF THE MOVING PARTS AND CAN CAUSE SERIOUS DAMAGE.

CAUTION

USED OIL CAN HARM THE ENVIRONMENT. COLLECTION AND DISPOSAL SHOULD BE CARRIED OUT IN COMPLIANCE WITH CURRENT REGULATIONS.

CAUTION

AN EXCESSIVE QUANTITY OF OIL CAN LEAD TO LEAKAGE, WHICH MAY CAUSE THE ENGINE AND THE WHEEL TO GET DIRTY.

CAUTION

WHEN REPLACING THE HUB OIL DO NOT LET THE OIL COME INTO CONTACT WITH THE REAR BRAKE DISC.

CAUTION

FOR OIL REPLACEMENT, CONTACT ANY AUTHORISED SERVICE CENTRE AS THEY ARE EQUIPPED TO DISPOSE OF USED OILS IN AN ENVIRONMENTALLY FRIENDLY AND LEGAL WAY.

Recommended products

AGIP ROTRA 80W-90

Rear hub oil

SAE 80W/90 Oil that exceeds the requirements of API GL3 specifications

Characteristic

Rear hub oil

250 cc

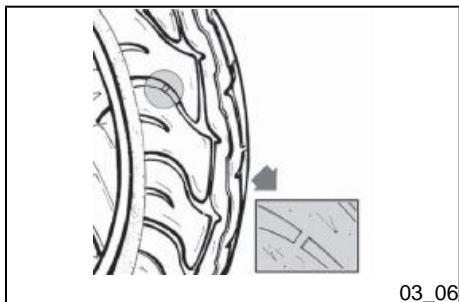

Tyres (03_06)

Check periodically (about every 500 km) the tyre pressure. The tyres are equipped with wear indicators; the tyres should be replaced as soon as these indicators become visible on the tyre tread. Also check that the tyres do not show signs of splitting at the side or irregular tread wear; if this occurs, go to an authorised workshop or at least a workshop equipped to perform the replacement.

CAUTION



TYRE PRESSURE SHOULD BE CHECKED WHEN TYRES ARE COLD. INCORRECT TYRE PRESSURE CAUSES ABNORMAL TYRE WEAR AND MAKES RIDING DANGEROUS.

TYRES MUST BE REPLACED WHEN THE TREAD REACHES THE WEAR LIMITS SET FORTH BY LAW.

TYRES

Front tyre

Without inner tube 120/70-12" 51P

Rear tyre

Without inner tube: 130/70-12" 62P

TYRE PRESSURE

Front tyre pressure

1.8 bar

Rear tyre pressure

2 bar

Rear tyre pressure - driver and passenger

2.2 bar

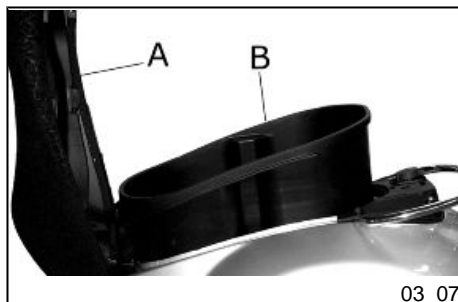

03_07

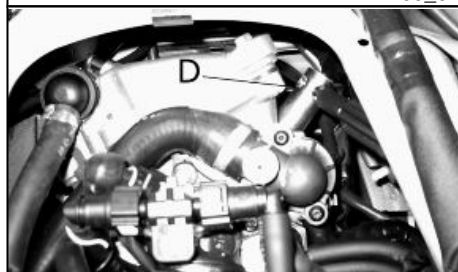

03_08

Spark plug dismantlement (03_07, 03_08)

Proceed as follows:

1. lift the saddle «A»
2. lift the helmet compartment «B» and reach into the spark plug with your hand;
3. disconnect cap of the spark plug HV wire;
4. unscrew the spark plug using the spark plug spanners «D» supplied;
5. When refitting, place the spark plug in the hole at the due inclination and screw it by hand until it is finger tight;
6. use the box-spanner«D» supplied only for locking;
7. place cap fully over the spark plug.

WARNING

THE SPARK PLUG MUST BE REMOVED WHEN THE ENGINE IS COLD. THE SPARK PLUG MUST BE REPLACED EVERY 20,000 KM. USE OF ELECTRONIC CONTROL UNITS OR ELECTRONIC IGNITIONS DIFFERING FROM THOSE RECOMMENDED CAN SERIOUSLY DAMAGE THE ENGINE.

CAUTION

THE USE OF SPARK PLUGS OTHER THAN THOSE RECOMMENDED OR A SHIELDLESS SPARK PLUG CAP COULD CAUSE DISTURBANCES TO THE SYSTEM.

Characteristic

Recommended spark plug

Champion RG 4 PHP

Removing the air filter (03_09, 03_10, 03_11, 03_12)

Proceed as follows:

1. unscrew the fixing screw «A».
2. unscrew the nut «B» under the body.
3. remove the left side fairing;
4. remove the helmet compartment;
5. unscrew the fixing screws «C» that can be reached after the helmet compartment has been removed;
6. unscrew the screws «D» and remove the air filter cover.

Remove the filtering element and clean it with water and shampoo; then dry it with a clean cloth and short blasts of compressed air. Finally, immerse it in a mixture containing 50% oil of the recommended type and 50% petrol. Then gently squeeze the filter element between your hands, allow it to drip and then refit it. Possible oil or water deposits can be eliminated by removing the two rubber caps «E».

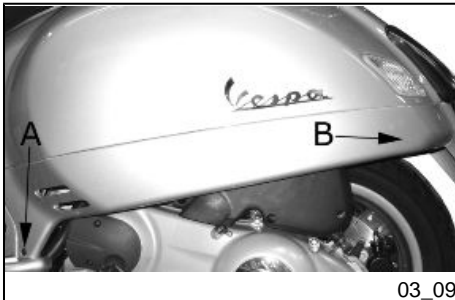

03_09



03_10

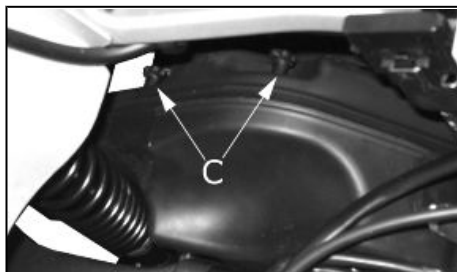

03_11

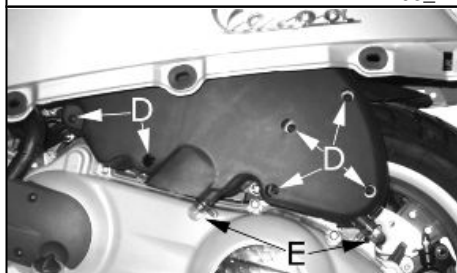

03_12



03_13

CAUTION

IF THE VEHICLE IS USED ON DUSTY ROADS IT IS NECESSARY TO CARRY OUT MAINTENANCE CONTROLS OF THE AIR FILTER TO AVOID DAMAGING THE ENGINE.

CAUTION

IN ORDER NOT TO DAMAGE THE VEHICLE PLASTIC COVERS CONTACT AN AUTHORISED SERVICE CENTRE TO HAVE THE AIR FILTER CLEANED.

Recommended products**AGIP FILTER OIL**

Oil for air filter sponge

Mineral oil with specific additives for increased adhesiveness

Cooling fluid level (03_13, 03_14)

Engine cooling is carried out by a forced-circulation coolant system; the cooling system holds about 2.100 ÷ 2.150 l of coolant- a mixture of 50% de-ionised water and 50% ethylene-glycol antifreeze solution and corrosion inhibitors. Recommended coolant, supplied with already mixed and ready for use fluid. For proper functioning of the engine, the coolant temperature needle should be within the middle zone of the scale between the 5th and 8th bar. If the needle points at the 10th bar, the instrument bars lit at that moment start flashing. Stop the engine, let it cool down and check the fluid level; if the level is OK, take your scooter to an **Authorised Piaggio Service Centre**. If when using your scooter at a low gear the coolant temperature exceeds the above values, shut off the engine and let it cool down. Then check the coolant level. If level is OK, take your scooter to an **Authorised Piaggio Service Centre**. The fluid



level must be checked every 10,000 kilometres with a cold engine, in the way shown below:

- a) Place the scooter in a vertical position on the stand.
- b) Unscrew the fixing screw «A» and remove the cover.
- c) Check the fluid level according to the two marks- MIN and MAX «B» on the reservoir
- d) Top up, if necessary, if the fluid level is below the MIN level on the scale inside the expansion tank. The fluid level must always be between MIN and MAX level

If the fluid is near the minimum level, top-up only when the engine is cold. If it is necessary to top up the coolant frequently, or if the expansion tank is completely dry, you should look for the cause in the cooling system. Have the cooling system checked at an **Authorised Piaggio Service Centre**. Coolant must be changed every 2 years at an **Authorised Piaggio Service Centre**.

WARNING



IN ORDER TO AVOID BURNS, DO NOT UNSCREW THE EXPANSION TANK CAP WHILE THE ENGINE IS STILL HOT.

WARNING



IN ORDER TO AVOID HARMFUL FLUID LEAKS WHILE RIDING, IT IS IMPORTANT TO MAKE SURE THAT THE LEVEL NEVER EXCEEDS THE MAXIMUM VALUE.

IN ORDER TO GUARANTEE THE PROPER FUNCTION OF THE ENGINE, IT IS NECESSARY TO KEEP THE RADIATOR GRILLE CLEAN.

Recommended products

SPECIAL AGIP PERMANENT fluid

coolant

Monoethylene glycol-based antifreeze fluid, CUNA NC 956-16

Checking the brake oil level (03_15, 03_16)

The brake fluid reservoirs are located on the pumps under the handlebar cover (front on the right-hand side, rear on the left-hand side). The procedures to checking the brake fluid level for the front and rear brakes are identical.

Proceed as follows:

1. rest the scooter on its centre stand and make sure the handlebar is centred;
2. check fluid level through the corresponding warning light «C».

A certain lowering of the level is caused by wear on the pads. Should the level appear to be below the minimum mark, please contact your nearest **PIAGGIO dealer or authorised service centre** in order to have a thorough inspection of the brake system carried out. Proceed as follows:

3. remove the tank cover «D» loosening the two screws «E» and refill reaching the correct level with the prescribed brake fluid type only and without exceeding the maximum level.

Under normal climatic conditions, the brake fluid should be replaced every 2 years. This operation must be carried out by trained technicians; take your scooter to a **PIAGGIO Dealer or authorised Service Centre**.

WARNING



ONLY USE DOT 4 CLASS BRAKE FLUIDS. COOLING SYSTEM FLUIDS ARE HIGHLY CORROSIVE. MAKE SURE THAT IT DOES NOT COME INTO CONTACT WITH THE PAINTWORK

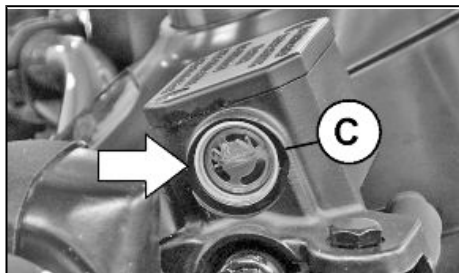

03_15



03_16

CAUTION

AVOID CONTACT OF BRAKE FLUID WITH EYES, SKIN, AND CLOTHING. IN CASE OF CONTACT, RINSE WITH WATER. THE BRAKING CIRCUIT FLUID IS HYGROSCOPIC, THAT IS, IT ABSORBS HUMIDITY FROM THE SURROUNDING AIR. IF THE HUMIDITY IN THE BRAKING FLUID EXCEEDS A CERTAIN VALUE, IT WILL LEAD TO INEFFICIENT BRAKING. NEVER USE BRAKING FLUID KEPT IN CONTAINERS THAT HAVE ALREADY BEEN OPENED, OR PARTIALLY USED.

Recommended products**AGIP BRAKE 4**

Brake fluid

FMVSS DOT 4 Synthetic fluid

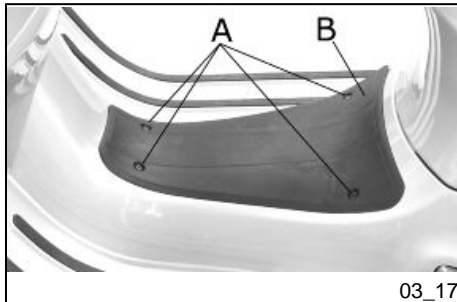
**Battery (03_17, 03_18, 03_19)**

To reach the battery **D**, proceed as follows:

1. rest the scooter on its centre stand;
2. unscrew the 4 screws «**A**», remove the footrest «**B**».
3. remove the two battery fixing screws «**C**».

The battery is the electrical device that requires the most frequent inspections and diligent maintenance. The main points of maintenance to be observed are as follows:

CAUTION

IN ORDER TO AVOID DAMAGING THE ELECTRICAL SYSTEM, NEVER DISCONNECT THE WIRING WHILE THE ENGINE IS RUNNING. DO NOT TIP THE SCOOTER TOO MUCH IN ORDER TO AVOID DANGEROUS LEAKAGE OF BATTERY ELECTROLYTE



03_18

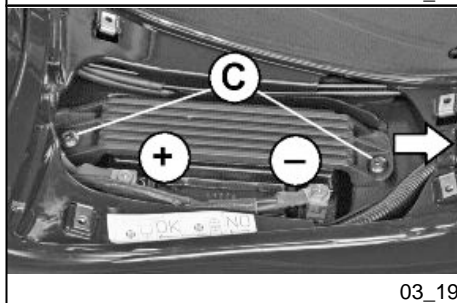

03_19

CAUTION

ELECTROLYTE CONTAINS SULPHURIC ACID: AVOID CONTACT WITH EYES, SKIN AND CLOTHES. IN THE CASE OF ACCIDENTAL CONTACT, RINSE WITH ABUNDANT OF WATER AND CONSULT A DOCTOR.

WARNING

SPENT BATTERIES ARE HARMFUL FOR THE ENVIRONMENT. COLLECTION AND DISPOSAL SHOULD BE CARRIED OUT IN COMPLIANCE WITH CURRENT REGULATIONS.

Electric characteristic**Battery**

12V - 12 Ah

Use of a new battery

Ensure that the terminals are connected correctly and check voltage.

CAUTION

DO NOT REVERSE THE POLARITY: RISK OF SHORT CIRCUIT AND DAMAGE TO THE ELECTRICAL SYSTEM.

WARNING

SPENT BATTERIES ARE HARMFUL FOR THE ENVIRONMENT. COLLECTION AND DISPOSAL SHOULD BE CARRIED OUT IN COMPLIANCE WITH CURRENT REGULATIONS.

Long periods of inactivity

Battery performance will decrease if the vehicle is not used for a long time. This is the result of the natural phenomenon of battery discharging plus residual absorption by vehicle components with constant power consumption. Poor battery performance may also be due to environmental conditions and the cleanliness of the poles. In order to avoid difficult starts and/or irreversible damage to the battery, follow any of these steps:

- **At least once a month** start the engine and run it slightly above idle speed for 10-15 minutes. This keeps all the engine components, as well as the battery, in good working order.
- Take your vehicle to a garage (as indicated in the "Vehicle not used for extended periods" section) to have the battery removed. Have the battery cleaned, charged fully and stored in a dry, ventilated place. Recharge **at least once every two months**.

N.B.

THE BATTERY MUST BE CHARGED WITH A CURRENT EQUAL TO 1/10 OF THE RATED CAPACITY OF THE BATTERY AND FOR NOT LONGER THAN 10 HOURS. CONTACT AN AUTHORISED SERVICE CENTRE TO CARRY OUT THIS OPERATION SAFELY. WHEN REFITTING THE BATTERY MAKE SURE THE LEADS ARE CORRECTLY CONNECTED TO THE TERMINALS.

WARNING

DO NOT DISCONNECT THE BATTERY CABLES WITH THE ENGINE RUNNING, THIS CAN CAUSE PERMANENT DAMAGE TO THE VEHICLE ELECTRONIC CONTROL UNIT.

WARNING

SPENT BATTERIES ARE HARMFUL FOR THE ENVIRONMENT. COLLECTION AND DISPOSAL SHOULD BE CARRIED OUT IN COMPLIANCE WITH CURRENT REGULATIONS.

Fuses (03_20, 03_21, 03_22)

The electrical system is equipped with:

1. six protection fuses «A» located in the glove compartment to the left
2. two fuses «B» located under the helmet compartment under the saddle hinge latch.
3. two fuses «C» located under the helmet compartment on the side fairing.

The chart shows the position and characteristics of the fuses in the vehicle.

CAUTION

BEFORE REPLACING THE BLOWN FUSE, FIND AND SOLVE THE FAILURE THAT CAUSED IT TO BLOW. NEVER TRY TO REPLACE THE FUSE WITH ANY OTHER MATERIAL (E.G., A PIECE OF ELECTRIC WIRE).

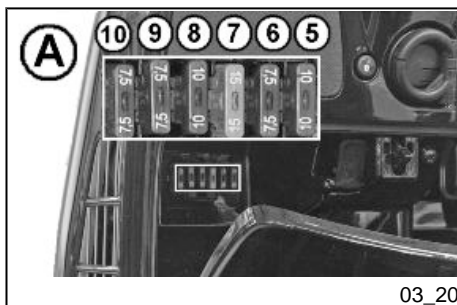

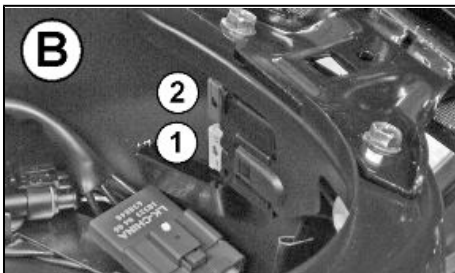

03_21

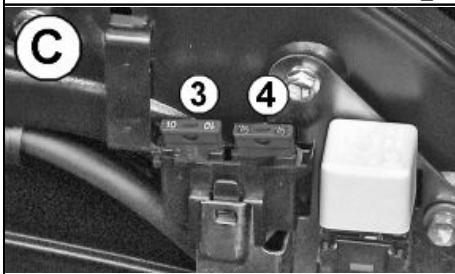

03_22

CAUTION

MODIFICATIONS OR REPAIRS TO THE ELECTRICAL SYSTEM, PERFORMED INCORRECTLY OR WITHOUT STRICT ATTENTION TO THE TECHNICAL SPECIFICATIONS OF THE SYSTEM, CAN CAUSE ERRORS IN FUNCTIONING AND RISK OF FIRE.

FUSES

No.1 - Vehicle main fuse	30A
No. 2 - Live injection ECU	7.5 A
No. 3 - Power to injection load	10A
No. 4 - Battery-powered injection ECU	7,5A
No. 5 - Live accessories and instrument panel	10A

No. 6 - Live light remote control and horn	7.5 A
No. 7 - Live Headlight and Saddle Opening Switch	15 A
No. 8 - Battery-powered Accessories and Instrument panel	10A
No. 9 - Live Stop light and Starter key	7.5 A
No. 10 - Power to tail light and instrument panel lighting	7.5 A

BULBS

Low-/ high-beam light	55/60 - 12V (Quantity 1)
Front position light	5W - 12V (Quantity 2)
Instrument Panel warning lights	1.2W - 12V (Quantity 5)
Front turn indicator light	5W - 12V (Quantity 4)
Rear turn indicator light	10W - 12V (Quantity 2)
Rear tail light	5W - 12V (Quantity 1)
Stop Light	16W - 12V (Quantity 1)
License Plate Light	5W - 12V (Quantity 1)

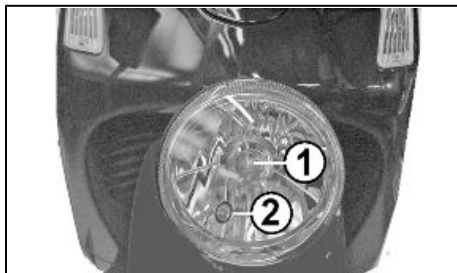

03_23

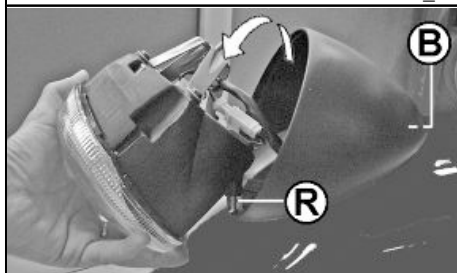

03_24

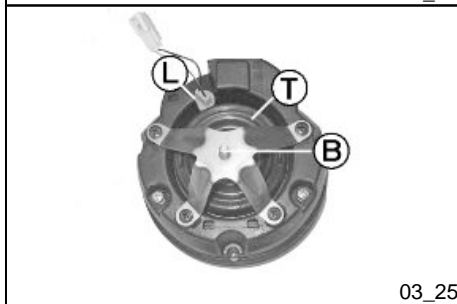

03_25

Front light group (03_23, 03_24, 03_25, 03_26, 03_27, 03_28)

WARNING



THE TWIN-FILAMENT (HIGH-BEAM AND LOW-BEAM) BULB IS HALOGEN: DO NOT TOUCH THE BULB WITH YOUR FINGERS TO AVOID COMPROMISING ITS FUNCTIONING

N.B.

IF MISTING IS NOTICED ON THE INSIDE OF THE HEADLAMP GLASS, THIS DOES NOT INDICATE A FAULT AND IS RELATED TO THE HUMIDITY AND/OR TO LOW TEMPERATURES.

THE PHENOMENON SHOULD QUICKLY DISAPPEAR WHEN THE LIGHT IS SWITCHED ON.

THE PRESENCE OF DROPS OF WATER, ON THE OTHER HAND, COULD INDICATE THAT WATER IS INFILTRATING. CONTACT THE PIAGGIO AFTER-SALES SERVICE NETWORK.

Electric characteristic

Bulbs

1 bulb, 12V/55-60W, for high- and low-beam lights

2 bulbs, 12V/5W, for taillights

To remove the front light assembly, proceed as follows:

1: Remove the nut «B» fixing the headlight to the mudguard.

2: Remove the headlight being careful with the set screw «R», then unhook the connectors of the electrical system.

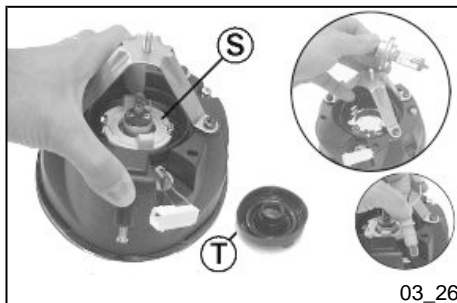

03_26

3. Remove the rubber cap «T» to reach the bulb holder, turn the ring nut «S» and take out the high-/low-beam light bulb. «1»; to facilitate access unscrew the screw «V» as well.

4. To replace the tail light bulb «L», in the headlight, remove the rubber bulb holder from its seat by pulling it slightly.

5. To refit, repeat the operations but in reverse order.

To remove the tail light on the shield, proceed as follows:

1: Remove the screw «A» of the front shield grille.

2: Rotate the front shield grille.

To replace the tail light, pull out the rubber lamp holder from its fitting. To reassemble, repeat the operation in the reverse order.

Headlight adjustment (03_29, 03_30)

Proceed as follows:

1. Place the vehicle in running order and with the tyres inflated to the prescribed pressure, on a flat surface 10 m away from a white screen situated in a shaded area, making sure that the longitudinal axis of the vehicle is perpendicular to the screen;

2. Turn on the headlight and check that the borderline of the projected light beam on the screen is not lower than 9/10 of the distance from the ground to the centre of vehicle headlamp and higher than 7/10;

3. Otherwise, adjust the headlight operating on the set screw «R» reached from under the front mudguard.

N.B.

THE ABOVE PROCEDURE COMPLIES WITH THE EUROPEAN STANDARDS REGARDING MAXIMUM AND MINIMUM HEIGHT OF LIGHT BEAMS. REFER TO THE STATUTORY REGULATIONS IN FORCE IN EVERY COUNTRY WHERE THE vehicle IS USED.

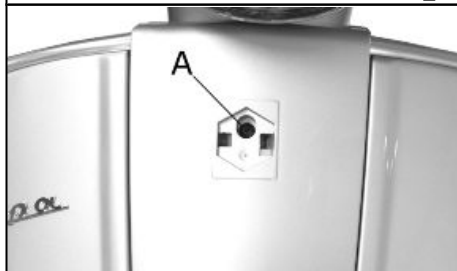

03_27

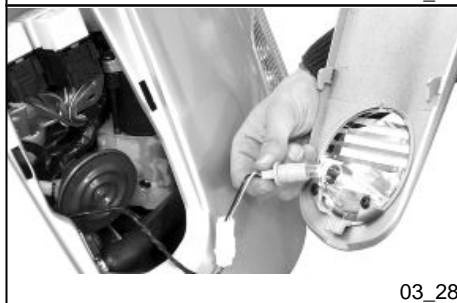

03_28

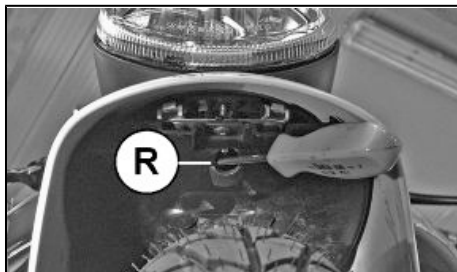

03_29

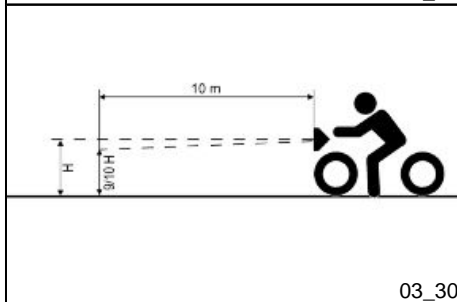

03_30



03_31

Front direction indicators (03_31)

To replace the front turn indicator bulbs, remove the tail light taking out the retaining screw "A", remove the bulb holder from its fitting; gently turn the bulb around 30° and remove it. Follow the process in reverse order to refit.



03_32

Rear optical unit (03_32)

Remove screw «A» to remove the rear headlight assembly.

Access to taillight bulbs, stop light bulb and license plate bulb.

To reassemble, repeat the operation in the reverse order.

N.B.

IF MISTING IS NOTICED ON THE INSIDE OF THE HEADLAMP GLASS, THIS DOES NOT INDICATE A FAULT AND IS RELATED TO THE HUMIDITY AND/OR TO LOW TEMPERATURES.

THE PHENOMENON SHOULD QUICKLY DISAPPEAR WHEN THE LIGHT IS SWITCHED ON.

THE PRESENCE OF DROPS OF WATER, ON THE OTHER HAND, COULD INDICATE THAT WATER IS INFILTRATING. CONTACT THE PIAGGIO AFTER-SALES SERVICE NETWORK.

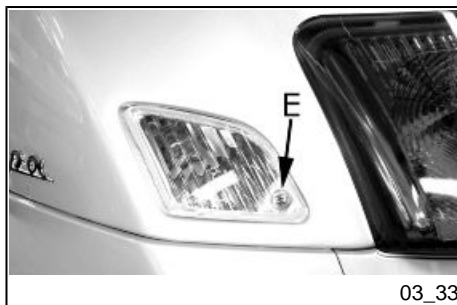

03_33

Rear turn indicators (03_33)

To gain access to the turn indicator bulbs, remove the fastening screws «E».

The bulbs have a bayonet coupling, to remove them press gently and twist anticlockwise about 30°. To refit follow the same steps but in reverse order.

Rear-view mirrors

Adjust the mirrors by applying slight pressure to the side of the mirror to move it to the desired position.



03_34



03_35

Front and rear disc brake (03_34, 03_35)

The brake disc and pad wear is automatically compensated, therefore it has no effect on the functioning of the front and rear brakes. For this reason it is not necessary to adjust the brakes. An excessively elastic brake lever stroke may indicate the presence of air in the braking circuit or a failure in the braking system. In this case, mainly due to the importance of brakes to guarantee safe riding conditions, the vehicle should be taken to an **Authorised Service Centre or Dealer**.

CAUTION



THE BRAKING ACTION SHOULD BEGIN AFTER ABOUT 1/3 OF THE BRAKE LEVER STROKE.

CAUTION



HAVE THE BRAKE PADS CHECKED BY THE DEALER ACCORDING TO THE CHECKS SPECIFIED IN THE SCHEDULED MAINTENANCE TABLE. HOWEVER, IN THE EVENT OF NOISES COMING FROM THE FRONT AND/OR REAR BRAKE SYSTEM DURING OPERATION, IT IS ADVISABLE TO HAVE THE BRAKE SYSTEM CHECKED BY A PIAGGIO DEALER OR AUTHORISED SERVICE CENTRE. AFTER REPLACING THE BRAKE PADS, DO NOT USE THE SCOOTER UNTIL YOU HAVE OPERATED THE BRAKE LEVER SEVERAL TIMES IN ORDER TO ALLOW THE PLUNGERS TO SETTLE AND THE LEVER STROKE TO BE SET TO THE CORRECT POSITION.

CAUTION



THE PRESENCE OF SAND, MUD, SNOW MIXED WITH SALT, ETC. ON THE ROAD, CAN DRASTICALLY REDUCE THE DURATION OF THE BRAKE PADS. IN

ORDER TO AVOID THIS, WE RECOMMEND WASHING THE VEHICLE FREQUENTLY WHEN RIDING IN THESE ROAD CONDITIONS.

Puncture (03_36)

The vehicle is equipped with tubeless tyres (without inner tube). In the event of a puncture, contrary to the situation with a tyre with inner tube, the tyre deflates more slowly, resulting in a greater steering safety. In the event of a puncture, it is admissible to make an emergency repair using an "inflate and repair" spray can. For a final repair, take your vehicle to an **Authorised Service Centre or Dealer**. The replacement of a tyre involves removing the wheel in question. Take your vehicle to an **Authorised Service Centre or Dealer** for these operations.

CAUTION



TO USE THE "INFLATE AND REPAIR" SPRAY PROPERLY FOLLOW THE INSTRUCTIONS ON THE PACKAGING.

WARNING



THE WHEELS FITTED WITH TYRES SHOULD ALWAYS BE BALANCED. RIDING THE VEHICLE WITH VERY LOW TYRE PRESSURE OR WITH INCORRECTLY BALANCED TYRES CAN LEAD TO DANGEROUS STEERING VIBRATIONS.

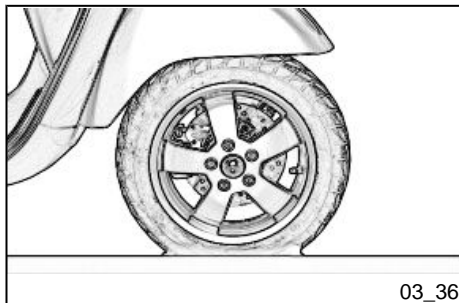



03_37

Periods of inactivity (03_37)

We recommend carrying out the following operations:

1. Clean the scooter thoroughly and then cover it with a canvas;
2. With the engine off and the piston in the bottom dead centre position, remove the spark plug, and pour into its hole 1 to 2 cc of the recommended oil. Operate the starter button 1-2 times for roughly 1 second to turn the engine over slowly, then insert the spark plug again;
3. Ensure that the **fuel tank is at least half full (in order to ensure the total immersion of the fuel pump)**; spread antirust grease on the unpainted metal parts; keep the wheels lifted above the ground by resting the chassis on two wooden wedges;
4. As regards the battery, follow the instructions in the "Battery" section.

Recommended products

AGIP CITY HI TEC 4T

Oil to lubricate flexible transmissions (throttle control)

Oil for 4-stroke engines



03_38

Cleaning the vehicle (03_38)

Use a low pressure water jet in order to soften the dirt and mud deposited on painted surfaces. Once softened, mud and dirt must be removed with a soft sponge for bodywork soaked in lots of water and shampoo (2-4% of shampoo in water). Then rinse abundantly with water, and dry with a shabby cloth. Any polishing with silicon wax must always be preceded by washing

WARNING



IF THE SCOOTER IS USED ON DUSTY ROADS IT IS NECESSARY TO SERVICE THE TRANSMISSION COVER FILTER SPONGE MORE FREQUENTLY.

CAUTION

DETERGENTS CAN POLLUTE WATER. THE VEHICLE MUST BE WASHED AT A WASH STATION EQUIPPED WITH A SPECIAL WATER PURIFICATION SYSTEM.

WARNING

THE USE OF A HIGH-PRESSURE WATER JET IS STRONGLY DISCOURAGED FOR ANY ENGINE CLEANING OPERATION; HOWEVER, IF NO OTHER MEANS ARE AVAILABLE, IT IS THEN NECESSARY TO:

- **ONLY USE FANLIKE SPRAY JETS.**
- **DO NOT PLACE THE WATER JET NOZZLE CLOSER THAN 60 CM.**
- **DO NOT USE WATER AT TEMPERATURES OVER 40°C.**
- **DO NOT USE HIGH-PRESSURE WATER JETS.**
- **DO NOT STEAM WASH.**
- **DO NOT DIRECT THE JET STRAIGHT TO THE WIRING AND SLOT DIFFUSER ON THE TRANSMISSION COVER.**

WARNING

NEVER WASH THE SCOOTER IN DIRECT SUNLIGHT, ESPECIALLY DURING SUMMER WHEN THE BODYWORK IS STILL HOT, AS THE SHAMPOO CAN DAMAGE THE PAINTWORK IF IT DRIES BEFORE BEING RINSED OFF. NEVER USE CLOTHS SOAKED IN PETROL, DIESEL OIL OR KEROSENE FOR CLEANING THE PAINTED OR PLASTIC SURFACES SO AS NOT TO DAMAGE THE LUSTRE FINISH OR ALTER THE MECHANICAL PROPERTIES.

CLEANING CHROME-PLATED PARTS

After cleaning chrome-plated parts, polish them with a specific product for chrome-plated, aluminium or stainless steel surfaces. To prevent corrosion, apply a protective spray on all the metal surfaces, including chrome- and nickel-plated ones. Apply spray oil and wax with moderation and make sure to wipe off excess product immediately.

CAUTION



NEVER APPLY OIL AND WAX ON RUBBER AND PLASTIC PARTS.

CAUTION



CHECK THAT THERE IS NO OIL OR WAX ON THE TYRES. BEFORE USING YOUR SCOOTER TEST ITS BRAKING EFFICIENCY AND BEHAVIOUR ON A BEND.

STARTING FAILURE

Emergency switch in «OFF»	Set the switch back to « ON »
Fuse blown	Replace the blown fuse and have the vehicle checked by an Authorised Service Centre.

IGNITION PROBLEM

Faulty spark plug	Contact an Authorised Service Centre.
Faulty ignition / injection control unit.	Contact an Authorised Service Centre.

Faulty coil. Due to the presence of high voltage, this check should only be carried out by an expert.	Contact an Authorised Service Centre .
---	---

LACK OF COMPRESSION

Loosen spark plug.	Screw in the spark plug tightly
Cylinder head loose, piston gas rings worn.	Contact an Authorised Service Centre .
Valve stuck	Contact an Authorised Service Centre .

HIGH CONSUMPTION AND LOW PERFORMANCE

Air filter blocked or dirty.	Clean with water and shampoo and impregnate with petrol and specific oil (section «Removing the air filter»)
------------------------------	--

INSUFFICIENT BRAKING

Greasy disc. Worn pads. Faulty braking system. Presence of air in the front and rear brake circuit.	Contact an Authorised Service Centre .
---	---

INEFFICIENT SUSPENSIONS

Shock absorber fault, oil leak, end buffer damaged; shock absorber preloading incorrectly set Contact an **Authorised Service Centre**.

IRREGULAR AUTOMATIC TRANSMISSION

Variator rollers and/or driving belt damaged Contact an **Authorised Service Centre**.

Vespa GTV 250 i.e.

Vespa®



Chap. 04
Technical data

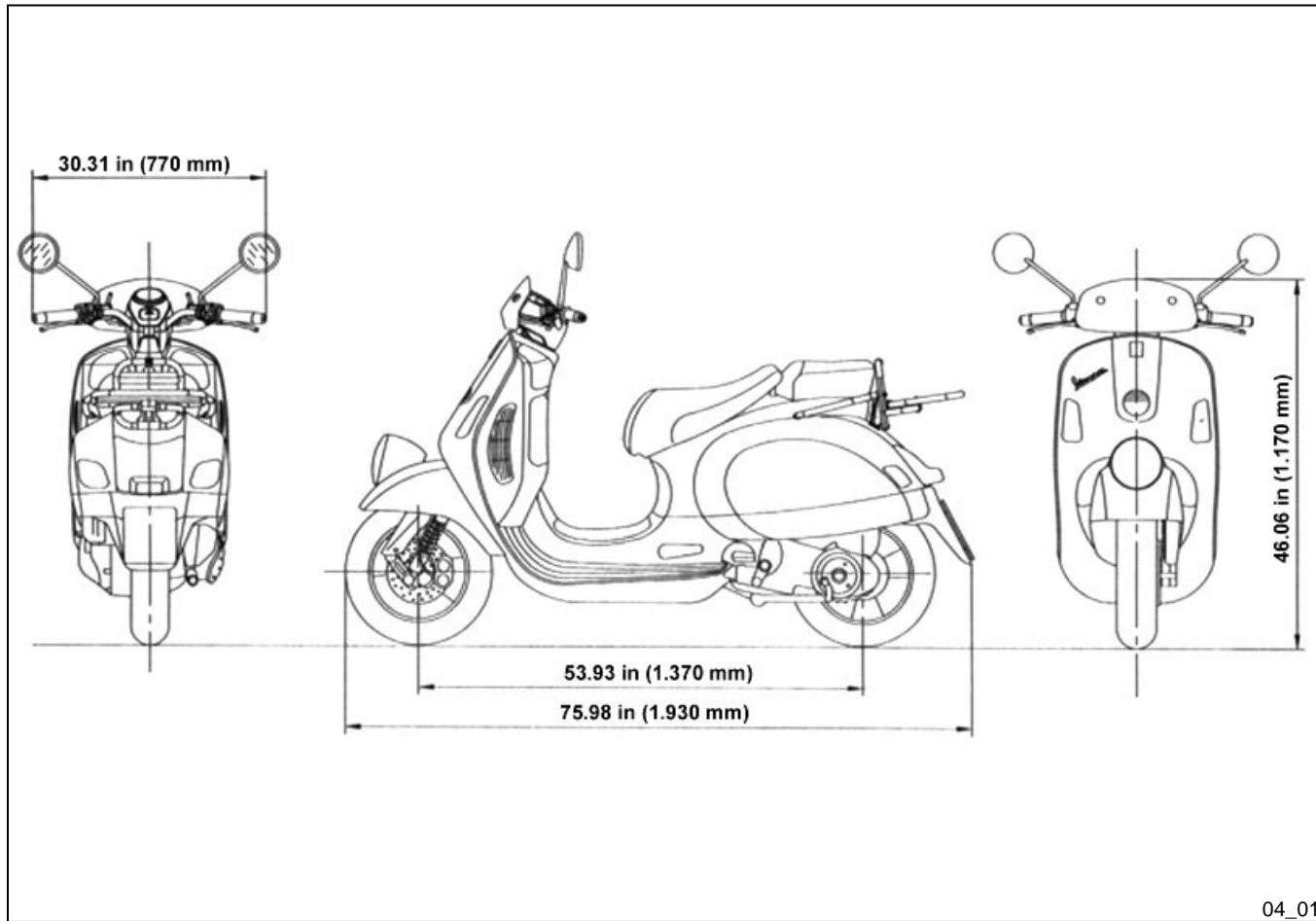

TECHNICAL DATA

Engine	single-cylinder four stroke
Bore x stroke	72 x 60 mm
Cubic capacity	244.29 cm ³
Compression ratio	10.5 - 11.5 : 1
Ignition advance (before TDC)	variable (integrated into the ignition system)
Spark plug	CHAMPION RG 4 PHP
Max. speed	120 km/h
Valve clearance	intake: 0.10 mm discharge: 0.15 mm
Overall length	1930 mm
Overall width	770 mm
Wheelbase	1370 mm
Overall height	1170 mm
Fuel supply	throttle valve dia. 32 mm and single injector
Exhaust muffler	absorption-type exhaust muffler with catalytic converter.
Electronic ignition	inductive, high efficiency integrated with the injection system, with variable timing and separate HV coil.
Lubrication	Engine lubrication with lobe pump (inside crankcase) controlled by a

	chain with double filter: mesh and paper.
Cooling	Forced fluid circulation, with engine driven pump; 3-way thermostat to pump intake.
Transmission	Automatic expandable pulley variator with torque server, V belt, automatic centrifugal dry clutch, gear reduction unit and transmission compartment with forced air circulation cooling.
Front brake	Ø 220 disc brake with hydraulic control activated by handlebar right lever.
Rear brake	disc brake, diameter 220 mm, with hydraulic servo operated from the handlebar with the left-hand lever.
Front wheel	Alloy rims: 12" x 3.00"
Rear wheel	Alloy rims: 12" x 3.00"
Front tyre	Without inner tube 120/70-12" 51P
Rear tyre	Without inner tube: 130/70-12" 62P
Front suspension	Single arm suspension (cantilever wheel) fitted with a dual-chamber hydraulic shock absorber with coaxial spring.
Rear suspension	single arm with two double-acting hydraulic shock absorbers and preloading adjustment in 4 positions.
Chassis	Stamped plate supporting body.

Kerb weight	146 ± 5 kg
Maximum admitted weight	~ 340 kg
Petrol tank	~ 9.2 l (approximate value)
Reserve	2÷2.5 l (approximate value)
Engine oil	Capacity: 1.3 l (dry) ; 1.2 l (when changing oil and filter)
Rear hub oil	Capacity approximately 250 cc
Cooling system	Capacity: ~ 2.100 ÷ 2.150 l



04_02

Kit equipment (04_02)

One box-spanner for spark plugs; one twin screwdriver; one special spanner for adjusting the rear shock absorber. The tools are arranged in the front case.

Vespa GTV 250 i.e.

Vespa®



Chap. 05
Spare parts and
accessories



05_01

Warnings (05_01)

WARNING



TO PREVENT ACCIDENTS AND TO GUARANTEE PROPER STABILITY, PERFORMANCE AND SAFETY, RIDE THE VEHICLE VERY CAREFULLY WHEN IT IS FITTED WITH ACCESSORIES OR WITH UNUSUAL LOADS.

WARNING



IT IS ALSO RECOMMENDED THAT "ORIGINAL PIAGGIO SPARE PARTS" BE USED, AS THESE ARE THE ONLY ONES OFFERING YOU THE SAME QUALITY GUARANTEE AS THOSE INITIALLY FITTED ON THE SCOOTER. THE USE OF NON-ORIGINAL SPARE PARTS RENDERS THE WARRANTY VOID.

WARNING



PIAGGIO MARKETS ITS OWN LINE OF ACCESSORIES THAT ARE RECOGNISED AND GUARANTEED FOR USE. IT IS THEREFORE ESSENTIAL, IN ORDER TO CHOOSE AND MOUNT THE ACCESSORIES CORRECTLY, TO CONTACT AN AUTHORISED DEALER OR SERVICE CENTRE. THE USE OF NON-ORIGINAL ACCESSORIES MAY AFFECT THE STABILITY AND OPERATION OF YOUR VEHICLE AND REDUCE SAFETY LEVELS WITH POTENTIAL RISKS FOR THE RIDER.

WARNING

NEVER RIDE THE SCOOTER EQUIPPED WITH ACCESSORIES (TOP BOX AND/OR WINDSHIELD) AT A SPEED HIGHER THAN 100 km/h.

THE SCOOTER CAN BE RIDDEN AT A HIGHER SPEED WITHOUT THE ACCESSORIES MENTIONED BEFORE WITHIN THE LIMITS ESTABLISHED BY LAW.

IF THERE SHOULD BE NOT-PIAGGIO ACCESSORIES INSTALLED, OR AN ABNORMAL LOAD, OR IF THE SCOOTER IS NOT IN A GENERALLY GOOD CONDITION, OR WHENEVER WEATHER CONDITIONS DEMAND IT, SPEED SHOULD BE REDUCED FURTHER.

WARNING

BE EXTREMELY CAREFUL WHEN INSTALLING AND REMOVING THE MECHANICAL ANTITHEFT DEVICE ON THE VEHICLE (U-SHAPED PADLOCK, DISC BLOCK, ETC.).

MAINLY DUE TO THE PROXIMITY TO THE BRAKE PIPES, TRANSMISSIONS AND/OR ELECTRIC CABLES, AN INCORRECT INSTALLATION OR REMOVAL OF THE ANTITHEFT DEVICE AS WELL AS LEAVING IT ON BEFORE STARTING THE VEHICLE CAN SERIOUSLY DAMAGE ITS COMPONENTS AND AFFECT THE CORRECT FUNCTIONING OF THE VEHICLE AND HARM THE USER.

Vespa GTV 250 i.e.

Vespa®



**Chap. 06
Programmed
maintenance**

Scheduled maintenance table

Adequate maintenance is fundamental to ensuring long-lasting, optimum operation and performance of your vehicle.

To this end, a series of checks and maintenance operations (at the owner's expense) have been suggested, which are included in the summary table on the following page. Any minor faults should be reported without delay to an **Authorised Service Centre or Dealer** without waiting until the next scheduled service to solve it.

All scheduled maintenance services must be carried out at the specified times, even if the stated mileage has not yet been reached. Carrying out scheduled services on time is necessary to ensure your warranty remains valid. For any further information concerning Warranty procedures and "Scheduled Maintenance", please refer to the "Warranty Booklet".

EVERY 2 YEARS

Coolant - change

Brake fluid - change

AFTER 1,000 KM

Safety locks - check

Throttle lever - adjustment

Engine oil - change

Electrical system and battery - check

Coolant level - check

Brake fluid level - check

Engine oil - replacement

Brake pads - check condition and wear

Tyre pressure and wear - check

Vehicle and brake test - road test

Hub oil - change

Steering - Check

**AFTER 5,000 KM; 25,000 KM; 35,000 KM; 55,000 KM;
65,000 KM**

Engine oil - level check/ top-up

Brake pads - check condition and wear

AT 10,000 KM 50,000 KM 70,000 KM

Safety locks - check

Throttle lever - adjustment

Air filter - clean

Air filter belt compartment - check

Engine oil - change

Electrical system and battery - check

Coolant level - check

Brake fluid level - check

Engine oil - replacement

Brake pads - check condition and wear

Sliding block / variable speed rollers - change

Tyre pressure and wear - check

Vehicle and brake test - road test

Hub oil - check

Suspensions - check

Steering - Check

AT 15,000 KM 45,000 KM 75,000 KM

Engine oil - level check/ top-up

Brake pads - check condition and wear

Driving belt - replacement

AT 20,000 KM; 40,000 KM; 80,000 KM

Spark plug - replacement

Throttle lever - adjustment

Air filter - clean

Air filter belt compartment - check

Engine oil - change

Valve clearance - check

Electrical system and battery - check

Coolant level - check

Brake fluid level - check

Engine oil - replacement

Brake pads - check condition and wear

Sliding block / variable speed rollers - change

Tyre pressure and wear - check

Vehicle and brake test - road test

Hub oil - change

Suspensions - check

Steering - Check

30,000 KM

Safety locks - check

Driving belt - replacement

Throttle lever - adjustment

Air filter - clean

Air filter belt compartment - check

Engine oil - change

Electrical system and battery - check

Coolant level - check

Brake fluid level - check

Engine oil - replacement

Brake pads - check condition and wear

Sliding block / variable speed rollers - change

Tyre pressure and wear - check

Vehicle and brake test - road test

Hub oil - check

Suspensions - check

Steering - Check

60,000 KM

Spark plug - replacement

Driving belt - replacement

Throttle lever - adjustment

Air filter - clean

Air filter belt compartment - check

Engine oil - change

Valve clearance - check

Electrical system and battery - check

Coolant level - check

Brake fluid level - check

Engine oil - replacement

Brake pads - check condition and wear

Sliding block / variable speed rollers - change

Tyre pressure and wear - check

Vehicle and brake test - road test

 Hub oil - change

 Suspensions - check

 Steering - Check

RECOMMENDED PRODUCTS TABLE

Product	Description	Specifications
AGIP ROTRA 80W-90	Rear hub oil	SAE 80W/90 Oil that exceeds the requirements of API GL3 specifications
AGIP CITY HI TEC 4T	Oil to lubricate flexible transmissions (throttle control)	Oil for 4-stroke engines
AGIP FILTER OIL	Oil for air filter sponge	Mineral oil with specific additives for increased adhesiveness
AGIP GP 330	Grease for brake levers, throttle	White calcium complex soap-based spray grease with NLGI 2; ISO-L-XBCIB2
AGIP CITY HI TEC 4T	Engine oil	SAE 5W-40, API SL, ACEA A3, JASO MA Synthetic oil
AGIP BRAKE 4	Brake fluid	FMVSS DOT 4 Synthetic fluid
SPECIAL AGIP PERMANENT fluid	coolant	Monoethylene glycol-based antifreeze fluid, CUNA NC 956-16

TABLE OF CONTENTS

A

Air filter: 40

B

Battery: 44, 45

Brake: 43, 54

C

Clock: 9

D

Disc brake: 54

E

Engine oil: 34, 35

Engine stop: 12

F

Fuel: 15

Fuses: 47

H

Headlight: 51

Horn: 11

Hub oil: 36

I

Identification: 18

Immobilizer: 12, 14

Instrument panel: 8

K

Key switch: 9

Keys: 12

L

Light switch: 11

M

Maintenance: 33, 71, 72

Mirrors: 53

S

Saddle: 16, 17

Scheduled maintenance: 72

Shock absorbers: 25

Spark plug: 39

Stand: 28

Start-up: 11

T

Tank: 15

Technical Data: 61

Top box: 19

Transmission: 29

Turn indicators: 53

Tyre pressure: 24

Tyres: 38



The descriptions and illustrations given in this publication are not binding. While the basic features as described and illustrated in this manual remain unchanged, PIAGGIO - GILERA reserves the right, at any time and without being required to update this publication beforehand, to make any changes to components, parts or accessory supplies, which it considers necessary to improve the product or which are required for manufacturing or construction reasons.

Not all versions shown in this publication are available in all Countries. The availability of individual versions should be confirmed with the official Piaggio sales network.

"© Copyright 2007 - PIAGGIO & C. S.p.A. Pontedera. All rights reserved. Reproduction of this publication in whole or in part is prohibited."

PIAGGIO & C. S.p.A. - After-Sales

V.le Rinaldo Piaggio, 23 - 56025 PONTEDERA (Pi)